



Table of Contents

Policy Statement	2
Online Specification Generators	3
Company Overview & Locations	4
Technologies & Innovations	6
Low-Slope Roofing	
Product Range	
Self-Adhered membranes with ADESO® Technology.....	16
APP (Plastomeric) Modified Bitumen Membranes.....	18
SBS (Elastomeric) Modified Bitumen Membranes.....	20
Quick ASTM Product Reference.....	22
Color Selection Chart for Low-Slope Modified Bitumen Cap Sheets.....	23
General Requirements & Design Criteria	
Low-Slope General Requirements.....	25
Requirements for Low-Slope Roof Decks.....	28
Requirements for Thermal Insulation on Low-Slope Roofing.....	30
Low-Slope Membrane Installation.....	30
Slope and Fastening Requirements.....	33
Re-Cover or Re-Roofing.....	34
Test Approvals and Classifications.....	35
Polyglass Tiered Contractor Program.....	35
Polyglass Warranty Program.....	35
Guide Specifications	
2-Ply Roof Systems.....	36
3-Ply Roof Systems.....	40
Roofing Details	44
Steep-Slope Roofing	
Product Range	
Polystick® Roof Underlayments.....	60
General Requirements & Design Criteria	
Low-Slope General Requirements.....	63
Steep-Slope Roofing Materials.....	63
Steep-Slope Membrane Installation.....	64
Guide Specifications	
1-Ply Roof Systems.....	66
2-Ply Roof Systems.....	69
Roofing Details	71

*While all information printed in this guide is accurate at time of publication, such information may change at any time with or without notice. For the most up to date information and data, please visit our website at polyglass.us.

Policy Statement

Polyglass products are intended for use in low-slope and steep-slope roofing applications, below-grade waterproofing and lining systems and liquid applied solutions. The general requirements and guide specifications in this manual are intended to assist architects, engineers, specifiers, owners and contractors in the design and construction process. This information should be used in conjunction with the recommendations provided by such bodies as the National Roofing Contractors Association (NRCA) in their most current Roofing & Waterproofing Manual, the Asphalt Roofing Manufacturers Association (ARMA), the International Building Code (IBC) and any other appropriate national or local codes (or code enforcement agencies), as well as pertinent recommendations of any other applicable third-party, Industry associations or manufacturers.

Polyglass offers this information as a guide for the satisfactory application of Polyglass products, and accepts no responsibility or liability for the design and construction of the building, roof deck, roof loads, wind designs or uses of the products in applications not contained within the published literature and specifications. Polyglass will not be responsible for the performance of its products when they are altered or damaged in anyway as a result of design, construction procedures, inclusions or omissions, and/or acts of God.

Applicability

Though Polyglass Modified Bitumen Roofing Systems are applicable for many residential, commercial and industrial roofing applications they may not be appropriate for uses other than those contained herein. For any application or use not covered here please contact the Polyglass Technical Services Department. Exceptions to these criteria shall have no validity unless provided in writing by an authorized, technically qualified Polyglass Technical Services representative.

Polyglass materials are not to be applied, without special consideration and written approval (as described above) by our Technical Services Department, where any of the following conditions exist:

- Roofs subject to chemical or by-product discharge.
- Buildings with large openings in a wall (greater than 10% of the wall surface) which could be left open in a storm.
- Roofs subject to regular traffic.
- Roofs subject to positive pressure situations such as: pressurized buildings, air-infiltrating decks, canopies, overhangs, airplane hangars, distribution centers, etc.
- Cold storage or freezer buildings or buildings with abnormally high interior temperatures.
- Swimming pools or other high humidity interior's (laundries, etc.)

Determination of satisfactory structural conditions for supporting the load of the completed roof installation as well as any other anticipated loads are the owner's, owner's engineer and/or architect's responsibility, not Polyglass'.

For roofs subject to code requirements or special job conditions, contact Polyglass Technical Services Department, a design professional and the local code official, prior to bidding.

Polyglass Guide Specifications are provided for the purpose of meeting the minimum requirements necessary to issue a Polyglass Warranty. Polyglass recommends that a design professional be consulted to assure proper design, installation, conformance to building codes, applicable wind designs, etc.

Safety

Refer to the General requirements of this manual, sections of important considerations from the NRCA "HARK" Manual regarding safety requirements/recommendations, as well as any other industry available documents which may address topics of concern with respect to safety, prior to the application of any roofing system. This manual is offered in good faith to support the professionally trained roofing contractor and others in the building/construction process, in making decisions with regard to use of, but not limited to, Polyglass products. Please note, although highly suggested herein for guidance, it is not an all-encompassing safety manual or training manual.

Phased Construction

Phased construction is a practice which is not recommended by NRCA (National Roofing Contractors Association). However, it is acknowledged that certain scheduling restrictions in new construction may require flexibility in construction. This may be in order to temporarily waterproof buildings and to avoid damage to, or impairment of, the completed roof membrane. For these situations Polyglass recommends the installation of a temporary roof as described in the NRCA "HARK". Polyglass membranes shall not be left "open" with regards to phased or over-night tie-ins, to ensure no water intrudes into a Polyglass system during any type of phasing.

Modifications

Any changes in, or variance, of the roofing system as published or manufactured by Polyglass, must be approved in writing by Polyglass, prior to the application of the Polyglass products. Polyglass at its discretion deserves the right to change or modify any of the information, recommendations, or specifications in its publication, without prior notice.

Warranty

For statements relating to the warranties please refer to the specific warranty (type). On non-warranted roofs, Polyglass acts only as the seller of materials, and has no control over the conditions under which the products are applied, whether by a Polyglass minimal tiered level Registered Contractor (or greater) or by another Contractor. Under these conditions, Polyglass assumes no responsibility for the performance of the roof beyond the obligation to manufacture and ship quality products that comply with published and ISO Certified Polyglass standards. Further, Polyglass assumes no responsibility for any damage resulting from use of the products in any improper manner.



Online Specifications Generators
Polyglass is listed! Find us on these Spec Generators online.



arcat.com



bsdspeclink.com



a product of The American Institute of Architects

avitr.com/specifications/masterspec/

For questions contact Polyglass Technical services Design Specialist at technical@polyglass.com

For full specifications on systems listed here, visit polyglass.us

Certifications

Polyglass SBS & APP membranes meet or exceed industry code approvals:

- UL Classified
- FM Approved
- ICC-ES
- Miami-Dade County Approved
- Florida Building Code
- Texas Department of Insurance
- CGSB
- Canadian Standards Association
- RCABC RoofStar
- CRRC



Full System Warranties available when installed by a Polyglass Preferred and Quantum Contractor. For more information contact info@polyglass.com.

About Polyglass

Polyglass is an ISO 9001:2015 Certified, leading manufacturer of modified bitumen roofing and waterproofing membranes and roof coatings for low- and steep-slope applications with over 30 years of experience in North America. Committed to adding value through innovation, Polyglass utilizes the most technologically advanced manufacturing process in the industry with six state-of-the-art manufacturing facilities- five in North America and one in Italy which services all of Europe.

Since 2008, Polyglass has been a part of the Mapei® Group, a multi-billion dollar manufacturer in the building industry with over 31 research centers and more than 83 production facilities in 36 countries.

Polyglass prides itself in innovative and quality roofing products which exceed the needs and expectations of its customers all around the world. This commitment is demonstrated daily by the people that work for Polyglass where the customers' needs always come first.



Research & Development

As a leading company in the modified bitumen membrane waterproofing and roofing products category, Polyglass has consistently innovated throughout its history. Our patent portfolio includes but not limited to: "ADESO®" - a groundbreaking self-adhered, dual-compound membrane, "SEALLap® ULTRA" - an enhanced bonding method for self-adhered membranes, and "Polyfresko®" an unsurpassed energy savings membrane that delivers exceptional solar reflectance.

Our multidisciplinary Research & Development team is comprised of Ph.Ds., chemists, material scientists and chemical, civil and mechanical engineers that interact with other departments to play a critical role in the development of new products, processes, innovations and ideas. R&D contributes to achieving our company's goals through the optimization of the manufacturing process, by implementing cost effective and improved installation techniques and by controlling the selection and approval of raw materials ensuring our customers receive quality products at an exceptional value that meet and exceed environmental, health and safety regulations.

The Research & Development department embraces and understands the many difficulties of meeting the demands of the building and waterproofing industries and is well equipped to meet these future challenges. Our research laboratories are equipped with cutting edge analytical and physical testing equipment to push the boundaries in the development of novel and innovative products and technologies that better serve our customer's needs and expectations.



Our Locations

1. Deerfield Beach, FL
Polyglass USA, Inc.
North American Headquarters
2. Fernley, NV
Manufacturing Facility
3. Hazleton, PA
Manufacturing Facility
4. Winter Haven, FL
Manufacturing Facility
5. Waco, TX
Manufacturing Facility
6. Phoenix, AZ
Manufacturing Facility
7. Ponte di Piave, Italy
Polyglass SpA European
Headquarters





What is ADESO® Technology?

ADESO Technology revolutionized the modified bitumen industry by manufacturing dual-compound self-adhered (SA) membranes using a true APP or SBS formulation on the top weathering side and an aggressive self-adhered formulation on the bottom side of the reinforcement. ADESO Technology integrates patented features that enhance lap sealing and allows product design with a variety of customized surfaces.

Feature & Benefits

- Labor savings with fast and clean installation
- Safe, no open flame application
- Superior watertight sealing
- Versatile roof systems for commercial and residential projects
- Long-term warranty protection
- Adheres to a variety of substrates
- Polyester or fiberglass reinforced
- Polar products available for cold weather application (25°F – 60°F)



Dual Compound

Combines a true APP or SBS compound top weathering surface with an aggressive self-adhesive compound on the bottom surface.



SEALLap® ULTRA

Instant side lap bond, tested stronger than all other application methods. This SA to SA bond provides a completely monolithic seal.



Multiple Surface Solutions

Provides solution for any roofing system need, allows a wide variety of surfacing options



FASTLap®

Save time and labor with granule free end laps.



Competitor Granulated Cap Sheet



Polyglass FASTLap Granule Free End Laps

Product List

Polyflex® SA P

Polyflex® SA P FR

Polyfresko® G SA

Polyfresko® G SA FR

Elastobase® SA

Elastoflex SA Base

Elastoflex SA V

Elastoflex SA V FR

Elastoflex SA V Plus

Elastoflex SA V Plus FR

Elastoflex SA V Flashing Strips

Elastoflex SA V Polar Base®

Elastoflex SA P

Elastoflex SA P FR

Elastoflex SA P Polar Cap®

Polyfresko® G SBS SA

Polyfresko® G SBS SA FR

Polystick® XFR

Polystick® MTS Plus

Polystick® TU PLUS

Polystick® TU MAX

Polystick® TU P

Polystick® IR-Xe

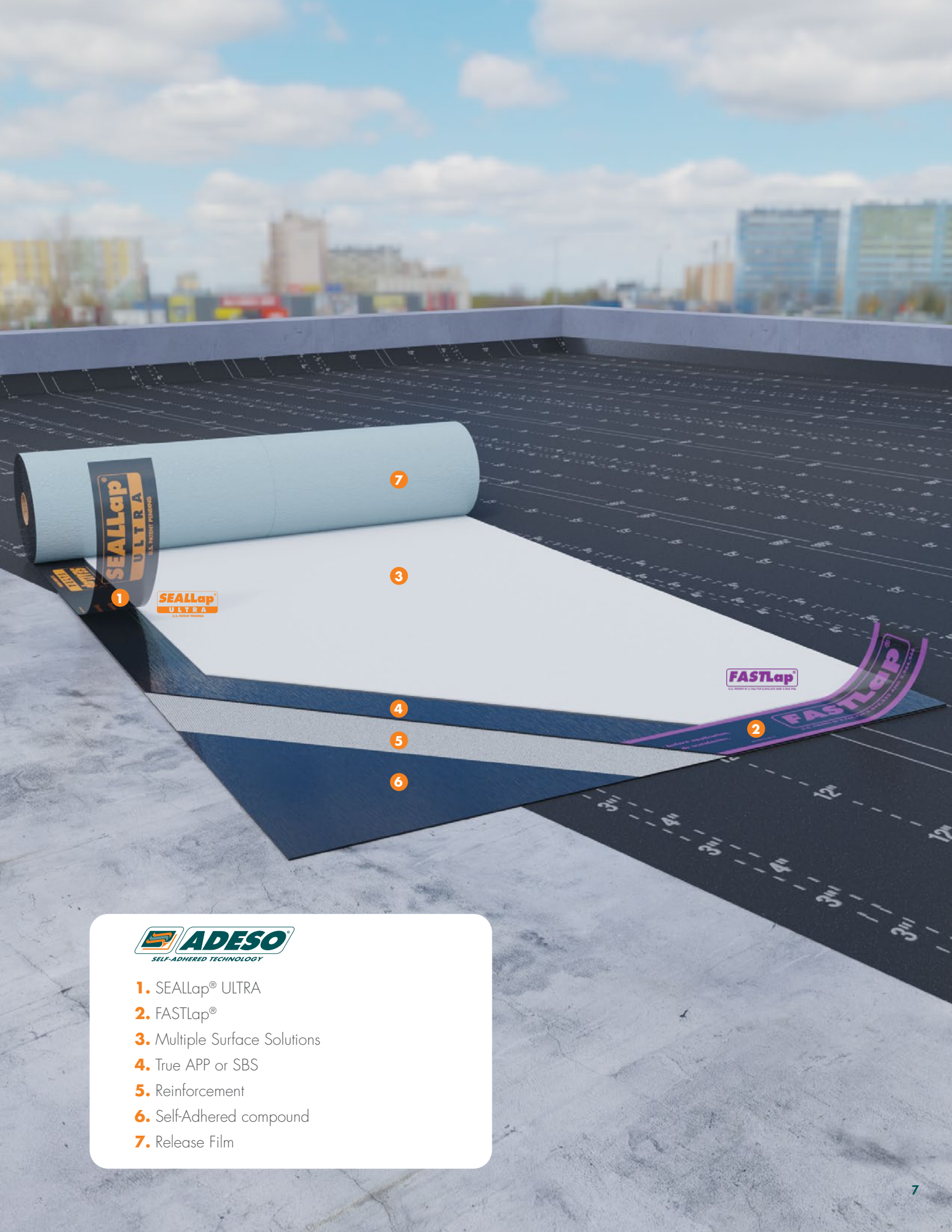

1

SEALLap
ULTRA
U.S. PATENT PENDING

7

3

4

5

6

FASTLap
U.S. PATENT PENDING

2



- 1. SEALLap® ULTRA
- 2. FASTLap®
- 3. Multiple Surface Solutions
- 4. True APP or SBS
- 5. Reinforcement
- 6. Self-Adhered compound
- 7. Release Film



What is CURE Technology®?

CURE Technology is a patented thin film technology, resulting in a modified bitumen membrane with greatly enhanced performance benefits without compromising the ease of installation and overall value expected from Polyglass products.

Features & Benefits

- Featured on all Polyfresko® cap sheets
- Vastly improved surface reflectivity and membrane emissivity
- Exceptional granule adhesion
- Ultraviolet stabilizers resulting in greater durability and longevity
- Minimal scorching with torch application
- Impact, scuff and stain resistant
- Mold and fungus resistant
- Solventfree and environmentally friendly



Stain-Free

Minimal staining on the surface of the cap sheet; significantly resists discoloration. Maintains its color integrity over time.



Granule Adhesion

Superior granule adhesion, minimal loss of granules when exposed to foot traffic and other elements.



Reflectivity

Initial reflectivity ratings above industry standards, maintains reflectivity performance over time.



Thin Film Technology

Minimal surface finishing while maintaining granule appearance, increased durability and improved reflectivity.

Product List

Polyfresko® G
 Polyfresko® G FR
 Polyfresko® G HP FR (Type II)

Polyfresko® G SBS
 Polyfresko® G SBS FR
 Polyfresko® G SBS HP FR (Type II)

Polyfresko® G SA
 Polyfresko® G SA FR
 Polyfresko® G SBS SA
 Polyfresko® G SBS SA FR

Why **POLYFRESKO** with **CURE** technology®?



Highly Reflective, Energy Efficient

Initial reflectivity above industry standards, eligible for LEED® points as part of qualified cool roof system

Durability

Premium membrane construction for superior durability

Protection

As part of a Polyglass multi-ply system, Class A Fire Rating with extended warranties available

Safe and secure

Enhanced performance benefits without compromising the ease of installation

Stain-free

Polyfresko will not discolor over time, resistant to surface blemishes and dirt pickup

Approved Substrates

- Various base membranes
- Concrete
- Refer to Polyglass published documentation for complete list of approved substrates.
- DensDeck®
- SECUROCK

Code Approvals*

- ASTM
- UL Classified
- FM Approved
- ICC-ES
- Florida Building Code
- Miami-Dade County Approved
- Texas Department of Insurance
- CRRC Listed
- Can be used to comply with 2016 Title 24 Part 6 Cool Roof Requirements

*See Product Data Sheet for product specific approvals.

	Rated Product ID #: 0616-0011a		
		Initial	Aged
	Solar Reflectance	0.77	0.68
	Thermal Emittance	0.90	0.88
<small>The ratings above are subject to CRRC rating program conditions, requirements, and limitations. Visit coolroofs.org for important information and disclaimers about CRRC rating conditions, requirements, and limitations.</small>			

Solar Reflectance Index (SRI) Initial: 96 Weathered: 83

VELOCIFLEX

HIGH WIND RESISTANT ROOF ASSEMBLY

Polyglass' Velociflex is a redundant, multi-ply roofing system offering multiple installation and assembly options. The base sheet is "loose-laid" and mechanically attached in the side laps, which allows for fast, efficient installation. Velociflex systems were independently tested providing for high speed wind protection up to 270 psf (pounds per square foot).

The Velociflex Advantage

✓ Meets 'Wind Load' Performance

Multiple base sheet and attachment pattern options, can exceed specification requirements

✓ Highly Reflective 'Kool Roof' Options

When installed with a Polyfresko® G cap sheet, the system can be used to comply with 2016 Title 24 Part 6 Cool Roof Requirements and achieves Solar Reflective Index: 96

✓ Long-Term Performance

Redundant, multi-ply, modified bitumen roof system reinforced with high strength polyester; great for new roofing, re-roofing and recover systems.

✓ Tested & Certified

UL Classified for use in Class A roofs, as listed in the latest UL "Roofing Materials and Systems Director," and Florida Building Code approved

✓ Watertight System

Acts as a temporary roof once base sheet seams are heat welded

✓ Self Venting System

"Loose-laid" base sheet reduces chances of blistering from substrate to membrane

✓ Economical

Base sheet is fastened in the seam only, reducing material and labor costs

Velociflex System Wind Ratings

Mechanically Fastened Base Sheets with Heat Welded Cap Sheets

Polyglass Base Sheet	Attachment Pattern*	Wind Uplift Resistance (psf)
Elastoflex S6	12" o.c.	90
Elastoflex S6	6" o.c.	120
Elastoflex S6 HP	18" o.c.	120
Elastoflex S6 HP	12" o.c.	165
Elastoflex S6 HP	6" o.c.	270
Polyflex	12" o.c.	165

* Attached within the 5" wide side lap (torch-sealed or heat-welded). Contact Polyglass Technical Support for approved fasteners and plates for desired wind uplift.

Mechanically Fastened Base Sheets with Cold Applied Cap Sheets**

Polyglass Base Sheet	Attachment Pattern*	Wind Uplift Resistance (psf)
Elastoflex S6 HP	18" o.c.	120
Elastoflex S6 HP	12" o.c.	165

** Cold Applied Cap Sheets adhered with Polyglass PG 350 adhesive or PolyPlus® 35.



Polyglass Cap Sheet
Heat welded or cold applied

Polyglass Base Sheet
(mechanically attached in-the-seam)

Heat-Welded Side Laps
Approved Fasteners and Plates

Roof Deck
Heavy Duty Steel or Concrete

Insulation
POLY THERM® Polyisocyanurate
(attachment same as base sheet)

POLYFLASH® 1C

**One Part
Flashing
Compound**

What is PolyFlash® 1C?

PolyFlash 1C is a one-component, moisture-cure, silane modified polyurethane, white flashing compound designed for sealing and waterproofing roofing details, flashings, and penetrations on a wide variety of roofing systems. When combined with PolyBrite® reinforcing polyester fabric this product can permanently solve typical and challenging flashing needs. Compatible for use over asphaltic membranes, polymer modified membranes (APP, SBS), conventional BUR, most Polyglass roofing membranes.

Features & Benefits

- Unique ability to be applied as an immediate, but temporary emergency leak repair over wet or damp surfaces
- High tensile strength
- Crack bridging capabilities
- Excellent early rain resistance
- Excellent waterproofing: <1.0 US perms
- UV resistant
- Minimal odor
- Durable
- Extensive application ambient temperature range (40°F to 122°F)
- User-friendly application
- Seals masonry, wood, curbs or vents, specialty gypsum sheathing products, roof drains, pitch pans, unusually shaped penetrations





What is Burn-Shield Technology®?

Polyglass' patent pending Burn-Shield Technology® offers fire resistance capable of achieving the highest level of fire ratings.

Featured on Polyglass' Polystick XFR

Polyglass Polystick XFR is a dual-purpose fire resistant and self-adhered waterproofing underlayment, combining two patented technologies to achieve the highest levels of performance.

- Robust 80 mils (2 mm) of waterproofing rubberized asphalt
- Utilizes ADESO® Dual-Compound Self-Adhered Technology
- Approved for applications up to 265°F



“Fire has met its match!”





LOW-SLOPE



Product Range

Self-Adhered membranes with ADESO® Technology

Product Name	Modifier	Mat	ASTM	Basic Use	Top Surface	Bottom Surface
Polyflex® SA P	APP	Polyester	D6222	Cap	Granules	Release Film
Polyflex® SA P FR	APP	Polyester	D6222	Cap	Granules	Release Film
Polyfresko® G SA	APP	Polyester	D6222	Cap	Granules	Release Film
Polyfresko® G SA FR	APP	Polyester	D6222	Cap	Granules	Release Film
Elastobase® SA	SBS	Fiberglass	D1970; D4601	Base	Film	Release Film
Elastoflex SA Base	SBS	Polyester	D6164	Base	Film	Release Film
Elastoflex SA V	SBS	Fiberglass	D1970; D6163	Base/Interply	Film	Release Film
Elastoflex SA V FR	SBS	Fiberglass	D1970; D6163	Base/Interply	Film	Release Film
Elastoflex SA V Plus	SBS	Fiberglass	D6163	Base/Interply	Film	Release Film
Elastoflex SA V Plus FR	SBS	Fiberglass	D6163	Base/Interply	Film	Release Film
Elastoflex SA V Polar Base®	SBS	Fiberglass	D1970; D6163	Base/Interply	Film	Release Film
Elastoflex SA P	SBS	Polyester	D6164	Cap	Granules	Release Film
Elastoflex SA P FR	SBS	Polyester	D6164	Cap	Granules	Release Film
Elastoflex SA P Polar Cap®	SBS	Polyester	D6164	Cap	Granules	Release Film
Polyfresko® G SBS SA	SBS	Polyester	D6164	Cap	Granules	Release Film
Polyfresko® G SBS SA FR	SBS	Polyester	D6164	Cap	Granules	Release Film

LOW-SLOPE

PRODUCT RANGE

GENERAL REQUIREMENTS

SPECIFICATIONS

DETAILS

Product Range



Application Method	Net Coverage (Approx)	Weight	Nominal Thickness	Length	Width	Rolls/Pallet	UL
Self-Adhered	100 ft ² (9.3 m ²)	89 lbs (40 kg)	142 mils (3.6 mm)	32'10" (10 m)	39 3/8" (1 m)	20	✓
Self-Adhered	100 ft ² (9.3 m ²)	89 lbs (40 kg)	142 mils (3.6 mm)	32'10" (10 m)	39 3/8" (1 m)	20	✓
Self-Adhered	100 ft ² (9.3 m ²)	90 lbs (41 kg)	160 mils (4.0 mm)	32'10" (10 m)	39 3/8" (1 m)	20	✓
Self-Adhered	100 ft ² (9.3 m ²)	90 lbs (41 kg)	160 mils (4.0 mm)	32'10" (10 m)	39 3/8" (1 m)	20	✓
Self-Adhered	200 ft ² (18.5 m ²)	86 lbs (39 kg)	65 mils (1.65 mm)	65'8" (20 m)	39 3/8" (1 m)	25	✓
Self-Adhered	150 ft ² (13.9 m ²)	94 lbs (43 kg)	100 mils (2.5 mm)	49' 3" (15 m)	39 3/8" (1 m)	20	✓
Self-Adhered	200 ft ² (18.5 m ²)	94 lbs (43 kg)	80 mils (2.0 mm)	65'8" (20 m)	39 3/8" (1 m)	25	✓
Self-Adhered	200 ft ² (18.5 m ²)	94 lbs (43 kg)	80 mils (2.0 mm)	65'8" (20 m)	39 3/8" (1 m)	25	✓
Self-Adhered	150 ft ² (13.9 m ²)	92 lbs (42 kg)	100 mils (2.5 mm)	49'3" (15 m)	39 3/8" (1 m)	20	✓
Self-Adhered	150 ft ² (13.9 m ²)	92 lbs (42 kg)	100 mils (2.5 mm)	49'3" (15 m)	39 3/8" (1 m)	20	✓
Self-Adhered	200 ft ² (18.5 m ²)	95 lbs (43 kg)	80 mils (2.0 mm)	65'8" (20 m)	39 3/8" (1 m)	20	✓
Self-Adhered	100 ft ² (9.3 m ²)	84 lbs (38 kg)	140 mils (3.5 mm)	32'10" (10 m)	39 3/8" (1 m)	20	✓
Self-Adhered	100 ft ² (9.3 m ²)	84 lbs (38 kg)	140 mils (3.5 mm)	32'10" (10 m)	39 3/8" (1 m)	20	✓
Self-Adhered	100 ft ² (9.3 m ²)	90 lbs (41 kg)	140 mils (3.5 mm)	32'10" (10 m)	39 3/8" (1 m)	20	✓
Self-Adhered	100 ft ² (9.3 m ²)	88 lbs (40 kg)	142 mils (3.6 mm)	32'10" (10 m)	39 3/8" (1 m)	20	✓
Self-Adhered	100 ft ² (9.3 m ²)	88 lbs (40 kg)	142 mils (3.6 mm)	32'10" (10 m)	39 3/8" (1 m)	20	✓

Product Range

APP (Plastomeric) Modified Bitumen Membranes

APP modified asphalt roofing membranes, reinforced with polyester and/or fiberglass mat offer excellent tensile strength and dimensional stability. Polyglass APP membranes can be heat-welded and are designed to be applied directly over approved substrate or as part of a multi-ply system.

Product Name	Modifier	Mat	ASTM	Basic Use	Top Surface	Bottom Surface
Polybase V	APP	Fiberglass	D6509	Base	Film	Film
Polybond®	APP	Polyester	D6222	Base/Interply/Cap	Sand	Film
Polybond® G	APP	Polyester	D6222	Cap	Granules	Film
Polyflex®	APP	Polyester	D6222	Base/Interply/Cap	Sand	Film
Polyflex® (Talc Smooth)	APP	Polyester	D6222	Base/Interply/Cap	Talc	Film
Polyflex® 5.0	APP	Polyester	D6222	Base/Interply/Cap	Sand	Film
Polyflex® G	APP	Polyester	D6222	Cap	Granules	Film
Polyflex® G FR	APP	Polyester	D6222	Cap	Granules	Film
Polyflex® G HP	APP	Polyester	D6222, Type II	Cap	Granules	Film
Polyflex® G HP FR	APP	Polyester	D6222, Type II	Cap	Granules	Film
Modibond® G FR	APP	Polyester	D6222	Cap	Granules	Film
Polyfresko® G	APP	Polyester	D6222	Cap	Granules	Film
Polyfresko® G FR	APP	Polyester	D6222	Cap	Granules	Film
Polyfresko® G HP FR	APP	Polyester	D6222, Type II	Cap	Granules	Film

Product Range



Application Method	Net Coverage (Approx)	Weight	Nominal Thickness	Length	Width	Rolls/Pallet	UL
Heat Weld/ Mechanically Attached	200 ft ² (18.5 m ²)	111 lbs (51 kg)	80 mils (2.0 mm)	65'8" (20 m)	39 3/8" (1 m)	20	✓
Heat Weld	100 ft ² (9.3 m ²)	90 lbs (41 kg)	145 mils (3.7 mm)	32'10" (10 m)	39 3/8" (1 m)	23	✓
Heat Weld	100 ft ² (9.3 m ²)	100 lbs (45 kg)	160 mils (4.0 mm)	32'10" (10 m)	39 3/8" (1 m)	20	✓
Heat Weld/ Mechanically Attached	100 ft ² (9.3 m ²)	102 lbs (46 kg)	160 mils (4.0 mm)	32'10" (10 m)	39 3/8" (1 m)	23	✓
Heat Weld	100 ft ² (9.3 m ²)	88 lbs (40 kg)	155 mils (3.9 mm)	32'10" (10 m)	39 3/8" (1 m)	23	
Heat Weld	100 ft ² (9.3 m ²)	123 lbs (56 kg)	200 mils (5.0 mm)	32'10" (10 m)	39 3/8" (1 m)	20	✓
Heat Weld	100 ft ² (9.3 m ²)	115 lbs (52 kg)	180 mils (4.5 mm)	32'10" (10 m)	39 3/8" (1 m)	20	✓
Heat Weld	100 ft ² (9.3 m ²)	117 lbs (53 kg)	180 mils (4.5 mm)	32'10" (10 m)	39 3/8" (1 m)	20	✓
Heat Weld	100 ft ² (9.3 m ²)	110 lbs (50 kg)	180 mils (4.5 mm)	32'10" (10 m)	39 3/8" (1 m)	20	✓
Heat Weld	100 ft ² (9.3 m ²)	110 lbs (50 kg)	180 mils (4.5 mm)	32'10" (10 m)	39 3/8" (1 m)	20	✓
Heat Weld	100 ft ² (9.3 m ²)	106 lbs (48 kg)	160 mils (4.0 mm)	32'10" (10 m)	39 3/8" (1 m)	20	✓
Heat Weld	100 ft ² (9.3 m ²)	110 lbs (50 kg)	165 mils (4.2 mm)	32'10" (10 m)	39 3/8" (1 m)	20	✓
Heat Weld	100 ft ² (9.3 m ²)	117 lbs (53 kg)	165 mils (4.2 mm)	32'10" (10 m)	39 3/8" (1 m)	20	✓
Heat Weld	100 ft ² (9.3 m ²)	116 lbs (53 kg)	173 mils (4.4 mm)	32'10" (10 m)	39 3/8" (1 m)	20	✓

Product Range

SBS (Elastomeric) Modified Bitumen Membranes

SBS modified asphalt roofing membranes, reinforced with polyester and/or fiberglass mat, offer superior flexibility, excellent tensile strength and dimensional stability. Polyglass' SBS modified bitumen membranes are designed to be part of a multi-ply roof system.

Product Name	Modifier	Mat	ASTM	Basic Use	Top Surface	Bottom Surface
Modibase®	SBS	Fiberglass	D4601	Base/Interply	Sand	Sand
Elastovent®	SBS	Fiberglass	D4897	Base (Venting)	Sand	Granules
Elastobase® V	SBS	Fiberglass	D6163	Base	Film/Sand	Film/Sand
Elastobase® P	SBS	Polyester	D6164	Base	Film/Sand	Film/Sand
Elastoflex S6	SBS	Polyester	D6164	Base/Interply	Film/Sand	Film/Sand
Elastoflex S6 HP	SBS	Polyester	D6164, Type II	Base/Interply	Film/Sand	Film/Sand
Elastoflex S6 G	SBS	Polyester	D6164	Cap	Granules	Film/Sand
Elastoflex S6 G FR	SBS	Polyester	D6164	Cap	Granules	Film/Sand
Elastoflex S6 G HP	SBS	Polyester	D6164, Type II	Cap	Granules	Film/Sand
Elastoflex S6 G HP FR	SBS	Polyester	D6164, Type II	Cap	Granules	Film/Sand
Elastoflex V	SBS	Fiberglass	D6163	Base/Interply	Film/Sand	Film/Sand
Elastoflex V HP	SBS	Fiberglass	D6163, Type II	Base/Interply	Film	Film
Elastoflex V 22	SBS	Fiberglass	D6163	Base/Interply	Film/Sand	Film/Sand
Elastoflex V G	SBS	Fiberglass	D6163	Cap	Granules	Sand
Elastoflex V G FR	SBS	Fiberglass	D6163	Cap	Granules	Film/Sand
Elastoflex V G HP FR	SBS	Fiberglass	D6163, Type II	Cap	Granules	Film
Elastoshield® TS	SBS	Polyester	D6164	Base/Interply	Sand	Film
Elastoshield® TS G	SBS	Polyester	D6164	Cap	Granules	Film/Sand
Elastoshield® TS G FR	SBS	Polyester	D6164	Cap	Granules	Film/Sand
Polyfresko® G SBS	SBS	Polyester	D6164	Cap	Granules	Film
Polyfresko® G SBS FR	SBS	Polyester	D6164	Cap	Granules	Film
Polyfresko® G SBS HP FR	SBS	Polyester	D6164, Type II	Cap	Granules	Film

LOW-SLOPE

PRODUCT RANGE

GENERAL REQUIREMENTS

SPECIFICATIONS

DETAILS

Product Range

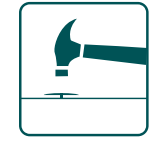

Application Method	Net Coverage (Approx)	Weight	Nominal Thickness	Length	Width	Rolls/Pallet	UL
Hot Mop, Cold Process, Mechanically Attached	300 ft ² (28 m ²)	78 lbs (35 kg)	50 mils (1.3 mm)	108' (33 m)	36" (0.914 m)	20	✓
Hot Mop, Mechanically Attached	100 ft ² (9.3 m ²)	79 lbs (36 kg)	130 mils (3.3 mm)	32'10" (10 m)	39 3/8" (1 m)	30	✓
Heat Weld, Hot Mop, Cold Process, Mechanically Attached	200 ft ² (18.5 m ²)	106 lbs (48 kg)	80 mils (2.0 mm)	65'8" (20 m)	39 3/8" (1 m)	20	✓
Heat Weld, Hot Mop, Cold Process, Mechanically Attached	200 ft ² (18.5 m ²)	100 lbs (45 kg)	87 mils (2.2 mm)	65'8" (20 m)	39 3/8" (1 m)	20	✓
Heat Weld, Hot Mop, Cold Process, Mechanically Attached	100 ft ² (9.3 m ²)	80 lbs (36 kg)	118 mils (3.0 mm)	32'10" (10 m)	39 3/8" (1 m)	25	✓
Heat Weld, Hot Mop, Cold Process, Mechanically Attached	100 ft ² (9.3 m ²)	80 lbs (36 kg)	118 mils (3.0 mm)	32'10" (10 m)	39 3/8" (1 m)	25	✓
Heat Weld, Hot Mop, Cold Process	100 ft ² (9.3 m ²)	102 lbs (46 kg)	160 mils (4.0 mm)	32'10" (10 m)	39 3/8" (1 m)	20	✓
Heat Weld, Hot Mop, Cold Process	100 ft ² (9.3 m ²)	102 lbs (46 kg)	160 mils (4.0 mm)	32'10" (10 m)	39 3/8" (1 m)	20	✓
Heat Weld, Hot Mop, Cold Process	100 ft ² (9.3 m ²)	106 lbs (48 kg)	160 mils (4.0 mm)	32'10" (10 m)	39 3/8" (1 m)	20	✓
Heat Weld, Hot Mop, Cold Process	100 ft ² (9.3 m ²)	106 lbs (48 kg)	160 mils (4.0 mm)	32'10" (10 m)	39 3/8" (1 m)	20	✓
Heat Weld, Hot Mop, Cold Process, Mechanically Attached	100 ft ² (9.3 m ²)	84 lbs (38 kg)	120 mils (3.0 mm)	32'10" (10 m)	39 3/8" (1 m)	25	✓
Heat Weld, Mechanically Attached	150 ft ² (13.9 m ²)	85 lbs (39 kg)	90 mils (2.2 mm)	49'3" (15 m)	39 3/8" (1 m)	25	✓
Heat Weld, Hot Mop, Cold Process, Mechanically Attached	150 ft ² (13.9 m ²)	85 lbs (39 kg)	90 mils (2.2 mm)	49'3" (15 m)	39 3/8" (1 m)	25	✓
Hot Mop, Cold Process	100 ft ² (9.3 m ²)	90 lbs (41 kg)	140 mils (3.5 mm)	32'10" (10 m)	39 3/8" (1 m)	20	✓
Heat Weld, Hot Mop, Cold Process	100 ft ² (9.3 m ²)	90 lbs (41 kg)	140 mils (3.5 mm)	32'10" (10 m)	39 3/8" (1 m)	20	✓
Heat Weld	100 ft ² (9.3 m ²)	84 lbs (38 kg)	140 mils (3.5 mm)	32'10" (10 m)	39 3/8" (1 m)	20	✓
Heat Weld, Mechanically Attached	100 ft ² (9.3 m ²)	99 lbs (45 kg)	160 mils (4.0 mm)	32'10" (10 m)	39 3/8" (1 m)	23	✓
Heat Weld, Hot Mop, Cold Process	100 ft ² (9.3 m ²)	108 lbs (49 kg)	180 mils (4.5 mm)	32'10" (10 m)	39 3/8" (1 m)	20	✓
Heat Weld, Hot Mop, Cold Process	100 ft ² (9.3 m ²)	108 lbs (49 kg)	180 mils (4.5 mm)	32'10" (10 m)	39 3/8" (1 m)	20	✓
Heat Weld	100 ft ² (9.3 m ²)	97 lbs (43 kg)	160 mils (4.0 mm)	32'10" (10 m)	39 3/8" (1 m)	20	✓
Heat Weld	100 ft ² (9.3 m ²)	97 lbs (43 kg)	160 mils (4.0 mm)	32'10" (10 m)	39 3/8" (1 m)	20	✓
Heat Weld	100 ft ² (9.3 m ²)	110 lbs (50 kg)	165 mils (4.2 mm)	32'10" (10 m)	39 3/8" (1 m)	20	✓

LOW-SLOPE

PRODUCT RANGE

GENERAL REQUIREMENTS

SPECIFICATIONS

DETAILS

Quick ASTM Product Reference

ASTM

D226	D1970	D2178	D4601	D6162
Type I PolyAnchor®	Elastobase® SA Elastoflex SA V Flashing Strips	Type IV Polyglass® Ply IV Type VI Polyglass® Ply VI	Modibase® Type II Elastobase® SA Polyglass® G2 Base PolyAnchor® UDL 40	Type III Elastoflex VP HT

ASTM

D6163	D4897	D6164	D6222	D6509
Type I Elastobase® V Elastoflex V Elastoflex V 22 Elastoflex V G Elastoflex V G FR Elastoflex SA V Elastoflex SA V FR Elastoflex SA V Plus Elastoflex SA V Plus FR Elastoflex SA V Flashing Strips Elastoflex SA V Polar Base® Type II Elastoflex V HP Elastoflex V G HP FR	Type II Elastovent®	Type I Elastobase® P Elastoflex S6 Elastoshield TS Elastoflex S6 G Elastoflex S6 G FR Elastoshield TS G Elastoshield TS G FR Polyfresko G SBS Polyfresko G SBS FR Elastoflex SA Base Elastoflex SA P Elastoflex SA P FR Elastoflex SA P Polar Cap® Polyfresko® G SBS SA Polyfresko® G SBS SA FR Type II Elastoflex S6 HP Elastoflex S6 G HP Elastoflex S6 G HP FR Polyfresko G SBS HP FR	Type I Polybond® Polybond® G Polybond® G FR Polyflex® Polyflex® (Talc-Smooth) Polyflex® 5.0 Polyflex® G Polyflex® G FR Modibond® G FR Polyfresko® G Polyfresko® G FR Polyflex® SA P Polyflex® SA P FR Polyfresko® G SA Polyfresko® G SA FR Type II Polyflex® G HP Polyflex® G HP FR Polyfresko® G HP FR	Polybase V

LOW-SLOPE

PRODUCT RANGE

GENERAL REQUIREMENTS

SPECIFICATIONS

DETAILS

Color Selection Chart for Low-Slope Modified Bitumen Cap Sheets

BLACK

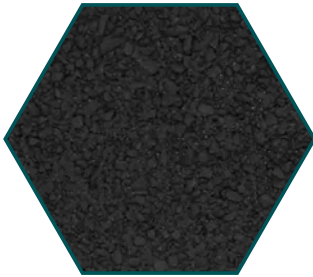

BUFF



CHESTNUT



GREY SLATE

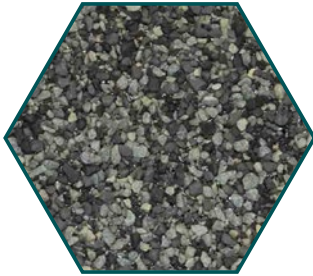

HEATHER BLEND



OAK



PINE GREEN

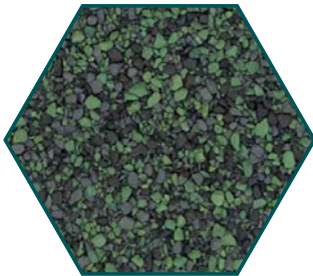

RED BLEND

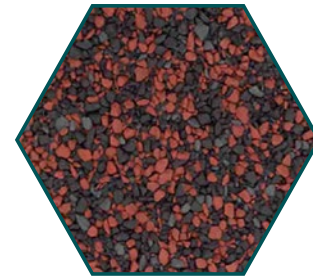

WEATHERWOOD



WHITE

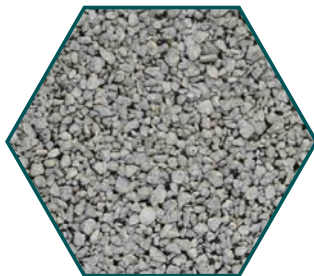

**POLYFRESKO®
HIGHLY REFLECTIVE WHITE**

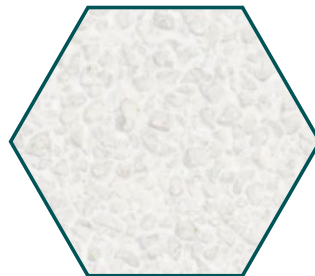

General Requirements and Design Criteria

- Part 1: Low-Slope General Requirements** 25
 - 1.0 General 25
 - 1.1 Quality Assurance 25
 - 1.2 Material Handling and Storage 25
 - 1.3 Cold Weather Installation 25
 - 1.4 Substrate and Preparation – New and Re-Roof Applications 26
 - 1.5 Vapor Retarders 27
 - 1.6 Special Applications 27
 - 1.7 Drainage 27
 - 1.8 Cants 27
 - 1.9 Wood Nailers 27
 - 1.10 Expansion Joints/Area Dividers 28
 - 1.11 Membrane Flashings 28
 - 1.12 Walkways and Protected Membranes 28
 - 1.13 Safety and Health 28
- Part 2: Requirements for Low-Slope Roof Decks** 28
 - 2.0 General Roof Deck (Substrate) Information 28
 - 2.1 Individual Deck Requirements 29
- Part 3: Requirements for Thermal Insulation on Low-Slope Roofing** 30
 - 3.0 General Thermal Insulation Information 30
 - 3.1 Insulation Installation and Attachment 30
- Part 4: Low-Slope Membrane Installation** 30
 - 4.1 Polyglass Self-Adhered (SA) Membranes with ADESO® Technology 30
 - 4.2 Polyglass APP & SBS Heat-Welded Membranes 31
 - 4.3 Polyglass SBS Hot Mop Membranes 32
 - 4.4 Polyglass SBS Cold-Applied Membranes 33
- Part 5: Slope and Fastening Requirements** 33
- Part 6: Re-Cover or Re-Roofing** 34
- Part 7: Test Approvals and Classifications** 35
- Part 8: Polyglass Tiered Contractor Program** 35
- Part 9: Polyglass Warranty Program** 35

General Requirements and Design Criteria

Part 1: Low-Slope General Requirements

1.0 General

- A.** Polyglass® U.S.A., Inc. specializes in Modified Bitumen roofing assemblies and offers a variety of products which utilize various application methods. Product labels should always be checked to ensure proper application.
- B.** Selection of assemblies is dependent upon a variety of factors which include (but not limited to) roof deck type, building type, use of the building and its occupancy, applicable code requirements as well as the environment of the location of the building.
- C.** Polyglass does not perform design, engineering or architecture and is not responsible for system performance issues resulting from faulty building construction or improper design. Selection of products, assemblies, and individual tested systems via accredited testing organizations such as Factory Mutual (FM), Underwriter Laboratories (UL) etc. shall remain the responsibility of others.
- D.** Polyglass offers the information found in this manual as a variety of recommendations for individual roof constructions to assist the design professional. It is the responsibility of both the design professional and/or material applicator to ensure compliance with all applicable codes and standards required for each project.
- E.** Polyglass materials must be protected from any damaging or aggressive discharges such as petroleum products, greases, any oils or animal fats. Where discharges in the roof vicinity are unavoidable, a suitable and permanently maintained separation or diverting mechanism should be used. Contact Polyglass Technical Services with questions.
- F.** Follow manufacturer's directions for protection of any materials used in the roofing operation prior to and during installation. Do not use materials which have been damaged.

1.1 Quality Assurance

- A.** As an ISO 9001:2015 Certified Company, Polyglass provides quality products worldwide.
- B.** Dependent upon the type of warranty requested or specified, roof observations may be required. Polyglass reserves the right to conduct roof observations to ensure quality of installation.
- C.** Polyglass provides installers assistance with a qualified team of technical field representatives. Please contact Technical Services or your local sales representative for information regarding the Technical Representative assigned to your region.
- D.** See PART 9: Polyglass Warranty Program for information regarding individual warranties offered.

1.2 Material Handling and Storage

- A.** Ensure all materials are stored in a manner which prevents them being exposed to moisture.
- B.** Materials should be examined when received. Damaged or unlabeled materials should not be used.

- C.** Materials must be stored in a dry area with adequate ventilation. Care should be taken to only remove stored materials that can be installed in a reasonable amount of time. All excess materials must be kept in storage.
- D.** Rolls shall be stored in an upright position with selva edge up on pallets.
- E.** Prior to beginning installation, remove all roll wrapping tape by cutting carefully and not ripping/damaging the material.
- F.** Polyglass does allow double stacking of pallets of membranes with the use of slip boards. Please see the Technical Bulletin online at www.polyglass.us for Rotation and Storage of Roll Products.
- G.** Polyglass self-adhered membranes to be stored at room temperature whenever possible and in an upright position on a flat surface. Avoid storing out of packaging for prolonged periods, especially above 88°F (31°C), in direct sunlight. Do not take the roll out of the packaging until it is ready for application. Refer to technical bulletins found at www.polyglass.us for more instruction on storage and handling.
- H.** Polyglass ADESO® membranes shall remain stored in boxes or wraps until time of application.
- I.** Polyglass Cold Applied Cements, Adhesives and Mastics shelf life is typically 18 months, if stored in original unopened containers – between 40°F–100°F (4°C–38°C). All containers should be sealed when not in use.

1.3 Cold Weather Installation

Polyglass advises against installing modified bitumen membranes at temperatures lower than 40°F–45°F (4°C–7°C) (wherever practicable). Where work is unavoidable at such temperatures, we recommend the following precautions be taken:

- A.** Take extra care during cold weather installation (Below ambient temperatures of 40°F–45°F (4°C–7°C), whereas ambient temperatures are affected by wind, humidity, etc.), to ensure adequate bonding is achieved between the surfaces to be joined. This applies to both material seam welds and adhesion of the applied product to the appropriately prepared substrate (substrate can be affected by such temperature constraints as well).
- B.** In addition, unrolling of cold materials, under very low ambient conditions must be avoided to prevent the likelihood of unnecessary stress cracking. The rolls must be at least 40°F (4°C) at the time of application. Should the membrane roll become stiff or difficult to install, it should be replaced with a new roll from the storage area. When unrolling in cold weather conditions (<40°F (4°C)) the center of the roll (closer to the core) will be colder and retain that colder temperature longer, making it more likely to stress crack.
- C.** To prevent the aforementioned situations and to ease the progress of installation under unfavorable conditions we recommend the following procedures:
 - 1.** The general recommendations of the National Roofing Contractors Association (NRCA) and Asphalt Roofing Manufacturers Association (ARMA) should be taken into account and will be helpful.

General Requirements and Design Criteria

2. Remember that wind chill will have an effect on the application temperature.
3. Ensure that membrane is only installed to properly dry, clean and primed (where necessary) surfaces as required by the specifications.
4. Store membrane, until immediately prior to installing the roll. Minimum ambient temperature of the storage area should be 55°F–60°F (13°C–15°C).
5. Once rolls of material are taken from the temperature controlled storage area, install before the temperature of the material drops below 40°F–45°F (4°C–7°C).

The following application specific recommendations should be followed:

Self-Adhered Application

For temperatures between 25°F–60°F (-4°C–16°C), use Polyglass® Elastoflex SA V Polar Base and Elastoflex SA P Polar Cap; ADESO® Self-Adhered membranes for cold weather application.

Heat-Welded Application

The use of shielded “dragon-wagons”, or moveable, flame-resistant wind shields can also be of great help in the effort to keep all surfaces and materials at a suitably warm temperature during heat-welding.

Hot Mop Application

Asphalt cools and thickens more quickly once removed from the heat source (tanker or kettle) and will not flow well, or give a uniform application rate. The following special precautions should be taken:

- A. All asphalt handling equipment should be insulated in order to minimize the drop-in asphalt temperature.
- B. For mop applied membranes, asphalt must be at least 400°F (204°C) (with a target temperature of 425°F (218°C)) or 20°F above the EVT (Equiviscous Temperature), whichever is higher, at the point of application.
- C. If minimum asphalt temperature of 400°F (204°C) cannot be maintained at the point of application, work should be discontinued.
- D. Never overheat asphalt to compensate for cold weather conditions.
- E. Mopping should not progress more than 5'–7' (1.5 m–2.1 m) in front of the roll at any time.

Cold Process Application

Cold process adhesives may become increasingly viscous and difficult to apply below 50°F (10°C). In such cases, extra care should be taken to ensure that the adhesives are applied at the proper rate and that humidity conditions are not conducive to condensation at the adhesive-membrane interface. Refer to Polyglass Product Sheets at www.polyglass.us for product specific cold weather application details. Do not proceed with application if inclement weather threatens. When temperatures are cold, store product in a heated area overnight.

1.4 Substrate and Preparation – New and Re-Roof Applications

Substrate and Preparation

- A. All surfaces to receive roofing must be properly clean and primed when necessary.

- B. It should be noted that proper preparation of the substrate relies on the installing contractor and/or building owner.
- C. When possible, construction of other trades prior to a finished roof application should be avoided. Protection of the finished roof is required when traffic from others is expected. Plywood, tarps, insulation, or other forms of protective sheathing should be applied prior to construction work.
- D. Substrates and decking must be evaluated to identify below deck conduit, fixtures, equipment, etc. that affect the installation of the roofing assembly.
- E. All rooftop units, supports, and penetrations that are to be removed should be removed prior to roof construction.
- F. Attention to termination heights, penetration heights, as well as membrane flashing heights should be given prior to roof construction to ensure proper clearance to receive new roofing.

New and Re-Roof Applications

- A. All surfacing or overburden materials, membranes, insulations, fasteners, membrane flashings, sheet metal flashings, and penetration flashings are to be completely removed.
- B. Existing roof decks may be contaminated with asphalt, adhesives, etc. from the prior roof system. Care should be taken when adhering rigid insulation boards and/or cover boards to the contaminated surface. Adhesion testing must be conducted to ensure a proper and efficient bond of the new materials.
- C. Irregular, or non-monolithic wall surfaces may need to be addressed to ensure a proper vertical surface to receive new membrane flashings.
- D. During the construction of the roofing assembly, temporary water cut-offs and tie-ins at the conclusion of each work day must be provided. The temporary materials must be removed and properly prepared at the beginning of roof construction the following workday.

Re-cover Applications

Re-cover applications include the application of a new roof directly over an existing roofing assembly. Many considerations should be given to the suitability of this application as not every existing roof system is a candidate for re-cover. It should be noted that it is the responsibility of the architect, engineer, contractor, or building owner to determine the suitability of a re-cover.

- A. A complete review and assessment of both the existing roof system as well as the support system should be conducted. A design professional or licensed engineer is highly recommended to evaluate the impact of the added weight of the new roof in addition to the existing system. As stated above, Polyglass does not practice engineering.
- B. The existing roof must be in sound condition and free of excessive defects.
- C. The substrate (existing system) must be free of excessive moisture.
- D. Existing roofing systems which contain 20%–25% moisture content are not a suitable candidate for re-cover and should be torn off.
- E. Moisture surveys are highly recommended to identify specific roof locations where moisture exists. Polyglass may require moisture scan on longer term warranted projects.

General Requirements and Design Criteria

- F. Test cuts may be used to evaluate the current condition of an existing roof on small projects.
- G. Any wet and/or deteriorated materials must be removed and replaced with like materials prior to installation of the new roof.
- H. All membrane flashings of the existing system must be removed and replaced.
- I. If existing membranes require ventilation, existing system/membrane must be cut in 10' × 10' (3 m × 3 m) areas.
- J. Systems requiring the use of one-way moisture relief vents, must have vents installed at one (1) per 1,000 ft² or 10 squares (93 m²).
- K. Temporary water cut-offs and tie-ins at the conclusion of each workday must be provided. The temporary materials must be removed and properly prepared at the beginning of roof construction the following workday.
- L. Coal Tar Pitch roof systems are typically an extensive re-cover and require particular attention. Please contact Polyglass Technical Services when considering a re-cover application.

1.5 Vapor Retarders

- A. Adequate moisture vapor control is recommended (when appropriate) as a lack thereof may result in the accumulation of moisture in the roofing assembly.
- B. An analysis of dew point and vapor flow should be assessed during an initial project design for the building as well as for re-roofing and re-cover applications as they can alter existing vapor flow.
- C. In general, vapor retarders may be required when high interior relative humidity is present. The condition is typically seen with food processing facilities, swimming pools, paper mills, laundry facilities, etc.
- D. Vapor retarders are sometimes referred to as temporary or secondary roofs.
- E. The necessity for use of a vapor retarder is the responsibility of the design professional and should be reviewed and approved by the building owner. The type, location and method of application is also to be determined by the design professional.
- F. The National Roofing Contractors Association (NRCA) as well as the American Society of Heating, Refrigerating and Air Conditioning Engineers (ASHRAE) may be referenced for recommendations on the necessity of a vapor retarder.

1.6 Special Applications

- A. Polyglass roofing assemblies are sometimes selected for installation over buildings that include unique environments and are deemed special purpose. These would include cold storage facilities, pools, as well as partially enclosed and open buildings such as hangars.
- B. These should be carefully reviewed as they pose design and building conditions such as elevated moisture or humidity, unusually elevated or lowered temperatures, and elevated pressure conditions.
- C. Special applications also include overburden or plaza deck assemblies. These typically include the addition of additional materials for protection of the newly installed roof.

- D. Technical Services should be contacted prior to these installations.

1.7 Drainage

- A. Adequate drainage is required for a well-functioning low-slope roof system. The minimum recommended slope is ¼" (6 mm) per foot.
- B. Absence of proper drainage often results in "Ponding". It is defined by the National Roofing Contractors Association (NRCA) as water that has not dissipated from the roof within 48 hours.
- C. Ponding water negatively affects the membrane and can result in premature deterioration, and is not covered by Polyglass warranties.
- D. The ideal structural roof deck is designed to provide adequate slope and drainage. When the roof deck has not been constructed to provide proper slope and drainage, the use of tapered insulation is required.
- E. Primary and secondary drains shall be of sufficient number and diameter and located so as to provide adequate drainage of the entire roof surface.
- F. The adequacy of drainage provisions, placement, sizing and/or number of drains required is the responsibility of the design professional. Drainage conditions should meet the requirements of codes as well as standard industry recommendations.

1.8 Cants

- A. Cant Strips are required at all horizontal/vertical intersections. They may be mechanically fastened or adhered to the substrate depending upon the deck type.
- B. Material type of Cant strip is dependent upon the application method of the roofing assembly. Hot asphalt applied systems may utilize Perlite (conforming to ASTM C728) or wood fiber (conforming to ASTM C208). Heat welded flashing assemblies require the use of Perlite only. Self-Adhered flashing applications are recommended to include wood Cant strip (primed).
- C. Roofing assemblies that do not include a Cant must incorporate the use of PolyFlash® 1C One Part Flashing Compound with reinforcement at the horizontal and vertical transition. Please contact Polyglass Technical Services for details on this application.

1.9 Wood Nailers

- A. It should be noted that both wood nailers and blocking materials are deemed as a component of the structure – not the roofing assembly. However, wood nailers are critical to the success of a well-performing roof.
- B. Care for selection of proper lumber used for nailers is important to ensure the selection of the appropriate type and level of corrosion resistance for fasteners.
- C. All nailers should be installed as per Factory Mutual (FM) LPDS 1-49 "Perimeter Flashing".
- D. ANSI/SPRI ES-1 should also be referenced for edge metal and parapet wall top conditions to ensure the installation of the nailer materials/attachment to resist calculated wind loads.

General Requirements and Design Criteria

1.10 Expansion Joints/Area Dividers

Expansion joints are part of the building, considerations such as design and location must be taken at the time of original building design by design professionals and reviewed by the building owner. The purpose of the expansion joint is to minimize stress on the building from movement.

- A. Per typical flashing details, expansion joints must be extended a minimum of 8" (20 cm) above the roof surface on curbs. Sheet metal caps or flexible expansion joint covers are used at the top surface of the expansion joint.
- B. Expansion joints must be located so as the typical drainage flow is not blocked.
- C. Expansion joints are continuous along the break in the structure. They shall not be terminated short of the end of the roof deck.

Area Dividers

- A. Area dividers can be similar to but are not considered expansion joints.
- B. Typical uses for dividers are to section off roof sections which were not included in original building design/construction. They can relieve stresses in an existing roofing system, and can serve as a separator between two dissimilar roofing materials.
- C. Area dividers are typically capped with a coping cap style sheet metal detail.

1.11 Membrane Flashings

- A. Membrane flashings and their locations are particularly volatile and are most susceptible to moisture penetration. Proper installation at these locations is critical to the integrity of the roofing assembly.
- B. Flashings, or, "Base Flashing", are locations on the roof whereby the field of the roof (horizontal surface) intersects with a wall, curb, penetrations (vertical surfaces), etc.
- C. Membrane flashings entail the installation of two (2) plies of membrane at flashing locations. The products associated with the flashings may utilize same plies used for the overall roofing assembly.
- D. Flashing locations that include irregularly shaped penetrations, low flashing clearance heights, or items too close to be properly flashed with membrane may be treated with PolyFlash 1C and PolyBrite Polyester Fabric in three-course fashion. Contact Technical Services for more information.
- E. Minimum flashing height is 8" (20 cm) above the deck and the maximum flashing height is 24" (61 cm). Membrane flashing can be taller than 24", only when terminated at every 24".
- F. Base flashings shall be mechanically fastened at the top edge and terminated with a proper termination bar and counterflashing.

1.12 Walkways and Protected Membranes

Walkways help protect the membrane from damage due to routine rooftop service traffic. Walkways may consist of an additional layer of similar Polyglass membrane of a contrasting color granulated surface, or another approved walkway system. The following are typical roof locations that utilize walkways:

- A. All roof access points (ladders, hatches, doorways, etc.).

- B. Areas subjected to traffic in excess of one monthly visit.
- C. Areas with high pedestrian traffic or subject to frequent maintenance operations.

In addition to typical locations requiring walkways, the walkway material may also be applied beneath rooftop equipment such as blocking to support gas/plumbing lines, and small non curb mounted HVAC (or other) equipment placed on wood sleepers.

1.13 Safety and Health

Strict Safety and Health precautions are necessary at all times. PLEASE READ, UNDERSTAND AND FOLLOW ALL INSTRUCTIONS ON LABELS AND PACKAGING AS WELL AS ANY APPLICABLE INDUSTRY STANDARDS AND REGULATIONS. See also all relevant sections above.

All volatile, or potentially volatile, materials such as primers, gas, cleaners, etc., shall be kept away from all ignition sources (e.g. flames, torches, fire, sparks, etc.). Consult product container labels and Safety Data Sheets for specific safety instructions.

The application of those products installed with hot asphalt or torch may result in burns and other physical injury. Surfaces which contact the melted bitumen or torch may ignite. The installer should take utmost care when using hot materials such as asphalt or when heat-welding any product. This is especially important when there may be a danger of contact with materials which may smolder, such as cellulose and wood materials, wood fiber, etc. or flammable or highly flammable solvents or chemicals.

Polyglass membranes may present a slip and fall hazard. This risk is increased when wet or icy conditions exist. Adequate precautions should be taken when working. Manufacturer recommends the use of OSHA approved fall protection for project conditions.

Cold Applied:

- A. DO NOT HEAT WITH AN OPEN FLAME.
- B. Clean equipment and over-spray with water.
- C. Clean hands with waterless hand cleaner.
- D. Application tools and equipment can be cleaned with odorless mineral spirits solvent. Recirculate through lines and spray equipment guns until residual coating is removed.
- E. DO NOT USE WATER OR RECLAIMED SOLVENTS.

1.14 Limitations

- A. Polyglass membranes should never be applied directly to TPO, EPDM, PVC, or other single ply membranes.
- B. Polyglass Cold Applied membranes are not to be used with organic saturated felts.
- C. Not to be installed over or under polystyrene insulation.

Part 2: Requirements for Low-Slope Roof Decks

2.0 General Roof Deck (Substrate) Information

- A. Polyglass is not responsible for design, selection, or performance of the deck. Roof decks are to be designed and

General Requirements and Design Criteria

constructed as per the deck manufacturers specifications and shall be suitable to receive a Polyglass roofing assembly.

- B. Prior to roof construction, the acceptance of the suitability of the substrate shall remain the responsibility of the applicator and/or the Authority Having Jurisdiction.
- C. Field verification of the suitability of the substrate shall include fastener withdrawal resistance, moisture content, as well as the overall condition of the substrate. Testing standards such as ANSI/SPRI FX-1 (withdrawal resistance), ANSI/SPRI 1A-1 (adhesion testing), as well as ASTM D4263 (surface moisture testing over concrete) shall be applied when assessing the condition of the substrate.
- D. Re-cover application may require the use of moisture scans to verify the moisture content of the assembly that currently in place.

2.1 Individual Deck Requirements

A. Steel Decks:

- 1. Minimum 22 gauge cold-formed steel decking with G-90 galvanized or minimum finish coat of primer paint on both sides. Galvanized steel decking where appropriate to project design criteria is recommended.
- 2. Deck panels are to be anchored to the supporting members by welding or mechanically fastening. Requirements as established by Factory Mutual for gauge and span should be in compliance with Factory Mutual (FM) LPDS 1-28 and 1-29.
- 3. Decks shall be clean and free of moisture and debris as well as free of corrosion.
- 4. Damaged or deflected panels as well as deteriorated portions must be removed and replaced.

B. Structural Concrete:

- 1. Decks shall me a minimum compressive strength of 2,500 psi with a minimum thickness of 4" (10 cm).
- 2. The surface is to be smooth, and free of ridges, sharp edges, and irregular surfaces.
- 3. The underside of the concrete deck must remain unobstructed to allow for the escape of moisture. This would include the applications of items such as paint, spray fireproofing etc.
- 4. Concrete decks typically require a minimum of 28 days cure time. Evaluation of determination of moisture content should be in accordance to ASTM D4263 (Plastic Sheet Method).
- 5. Field uplift resistance for adhesive applications is recommended as per ANSI/SPRI 1A-1.
- 6. Primers applied to the deck, when applied, must be dry prior to application of adhesives.
- 7. Cracks greater than 1/8" (3 mm) shall be filled or treated as per the direction of the deck manufacturer.

C. Cellular Lightweight Insulating Concrete:

- 1. Must have a minimum 200 psi compressive strength as well provide a minimum withdrawal resistance of 40 lbs (18 kg) as an average pull value.
- 2. Deck installation shall comply with the deck manufacturer.
- 3. Installation shall not proceed during inclement weather including both precipitation as well as freezing

temperatures. Any and all frozen deck sections shall be completely removed and replaced.

- 4. All measures should be taken to ensure that there is no entrapment of moisture within the deck prior to roofing applications.

D. Wood Plank:

- 1. Thickness to be a nominal 1" (2.5 cm) and width of 4"-6" (10 cm-15 cm).
- 2. Wood plank boards shall have a bearing on rafters at each end and must be securely fastened.
- 3. Boards shall be kiln-dried and preferably a tongue-and-groove style to eliminate the shrinkage or warping of planks.
- 4. Knotholes/cracks exceeding 1/4" (6 mm) must be covered with secured sheet metal.

E. Plywood:

- 1. Thickness to be a minimum of 1/2" (12 mm) with a minimum 4-ply conforming with C-D Exposure 1 grade.
- 2. The maximum joist spacing shall be 24" (61 cm) O.C. or less using minimum 1/8"-1/4" (3 mm-6 mm) spacing between panels.

F. Oriented Strand Board (OSB):

- 1. OSB shall be PS 2-10, Exposure 1, Structural 1 not less than 7/16" (11 mm) in thickness.
- 2. The sheathing is installed with all sides bearing on and secured to joists and cross blocking in accordance with the APA (Engineered Wood Association).

G. Cementitious Wood Fiber:

- 1. The application of cementitious wood fiber decking shall be in accordance to the individual deck manufacturer.
- 2. Panels shall be a minimum of 2" (5 cm) in thickness.
- 3. Panels must be protected from inclement weather when stored as well as during the application of the panels.
- 4. Joints between panels in excess of 1/4" (6 mm) as well as offsets in adjacent panels exceeding 1/8" (3 mm) must be grouted as per the panel manufacturer's instruction.

H. Gypsum:

- 1. Gypsum decks must have a minimum deck thickness of 2" (5 cm).
- 2. Panels shall be a minimum of 2" (5 cm) in thickness.
- 3. Panels must be protected from inclement weather when stored as well as during the application of the panels.
- 4. Joints between panels in excess of 1/4" (6 mm) as well as offsets in adjacent panels exceeding 1/8" (3 mm) must be grouted as per the panel manufacturer's instruction.

I. Poured reinforced concrete:

- 1. Shall be smooth, dry, clean and free of ice/frost, projections and depressions.
- 2. The concrete shall be fully cured and the surface shall be broom cleaned and free of release/curing agents prior to commencement of work.
- 3. The prepared concrete surfaces shall be primed with Polyglass PG 100 Fast-Drying Asphalt Primer ASTM Type D-41 at a rate of approximately 1 gallon/100 ft² (9.2 m²)
- 4. Polyglass requires no less than 30 days cure time for new concrete pours.

General Requirements and Design Criteria

5. All primed areas shall be fully dried before proceeding with the application of the roof system.

J. Other deck types:

Contact Polyglass for recommendations in any situation which involves other deck types, new or unusual deck construction.

Part 3: Requirements for Thermal Insulation on Low-Slope Roofing

3.0 General Thermal Insulation Information

The selection of insulation type and thickness is the responsibility of the architect, designer or building owner. Insulation must provide continuous support for all layers of the roofing system.

- A. Polyglass modified bitumen products may be installed directly over Polyglass Polytherm® or other approved polyisocyanurate insulation boards and certain other insulation materials. Most insulation manufacturers, however, require that a base sheet or Coverboard be mechanically attached to the deck or adhered to the insulation, when direct bonding isn't acceptable.
- B. Specific types and minimum thicknesses of Polytherm Insulation are available for use as a substrate for Polyglass membranes.
- C. Polytherm Insulation, or other suitable polyisocyanurate insulation boards, shall be provided with a suitable overlay board prior to mopping and with a suitable base sheet prior to heat welding of membrane.
- D. If Polyglass Polytherm Insulation is not used, consult Polyglass Technical Services for current information regarding the acceptability of other insulation types or manufacturers.
- E. Acceptable insulations: perlite, polyisocyanurate (ISO), ISO/perlite composite, expanded polystyrene (EPS)/perlite composite, phenolic, wood fiber, wood Fiber/ISO composite, glass fiber and cellular glass ("Foam glass"). Contact Polyglass for insulations not listed here.
- F. In general, all Polytherm Insulation must be installed in accordance with Polyglass requirements for installation. In the case of third-party manufacturers, the insulation manufacturer's instructions shall be strictly adhered to.

3.1 Insulation Installation and Attachment

- A. Incorrectly installed insulation can lead to roof system loss (blow-offs) and is the responsibility of the insulation installer, not the roof membrane manufacturer.
- B. Polyglass does not warrant against improperly attached insulation or insulation failure caused by incorrect application.
- C. All joints between layers should be staggered when multiple layers of insulation are installed.
- D. Insulation shall be kept dry at all times. Install only as much insulation as can be covered with completed roofing membrane before the end of the day's work (or prior to onset of inclement weather).
- E. Edges shall butt tightly, and all cuts shall fit neatly against adjoining surfaces to provide a smooth overall surface. Gaps of greater than ¼" (6 mm) width shall be filled with insulation.

- F. Install tapered insulation around roof drains and penetrations to provide adequate slope for proper drainage.
- G. Mechanically attached insulation shall be fastened in accordance with Factory Mutual (FM) Approvals requirements for the applicable geographic Zone with the required number (and type) of fasteners and plates. Exception: where Polyglass requirements are more stringent than Factory Mutual (FM) Approvals or third-party manufacturers, Polyglass requirements shall be followed.
- H. When asphalt or foam adhesive attachment is selected by the project designer, the proposed insulation shall be compatible with the roof substrate, the proposed bitumen and the requirements of the specific Polyglass membrane. NOTE: Expanded polystyrene (EPS) materials shall not be installed with hot bitumen products.
 - Maximum 4' x 4' (1.2 m x 1.2 m) insulation boards can be attached with hot asphalt.
 - Asphalt for insulation attachment shall meet ASTM D312 Type III or IV criteria, as dictated by the roof slope or other design conditions.

Part 4: Low-Slope Membrane Installation

Commence installation of the roofing system at the lowest point of the roof (or roof area), working up the slope toward the highest point. Lap sheets shingle fashion so as to constantly shed water. For further information contact Polyglass Technical Services. Follow the recommendations for the specific type of material and layer as outlined below, or as specified.

Type II standards, are acceptable for Polyglass roofing systems and should be appropriately installed in a manner approved for the specific product, e.g. fully adhered as self-adhered or with asphalt/or cold adhesive, heat-welded or mechanically attached (per industry standard fastening pattern), as applicable, and in accordance with specifications.

4.1 Polyglass Self-Adhered (SA) Membranes with ADESO® Technology

Polyglass self-adhered membranes are designed to provide a cleaner application, improve application speed and remove the need for torches, hot asphalt or bonding adhesives on the job site. Especially for job sites with limited access for special installation equipment or where using a propane torch or hot asphalt is undesirable or prohibited.

Surface Preparation

Polyglass self-adhered membranes may be applied directly to approved substrates such as; approved roof insulation, Polyglass film-surfaced base sheets and certain roof deck types. Do not apply directly to shingles, shakes, steep-sloped residential roof coverings or existing mineral surfaced roof membrane systems. Refer to Polyglass published Technical Bulletins regarding approved substrates.

General Requirements and Design Criteria

- A. Apply only in dry weather and when air and surface temperatures are 40°F (5°C) and rising. For temperatures between 25°F–60°F (-4°C–16°C), use Polyglass Elastoflex SA V Polar Base® and Elastoflex SA P Polar Cap® ADESO Self-Adhered membranes for cold weather application. Roofing installation shall not be conducted when any form of water, such as rain, dew, ice, frost, snow are present.
- B. All roof deck or substrate areas shall have positive drainage, be properly supported, structurally sound to support the live and dead load requirements of the roofing system, and sufficiently rigid to support construction traffic. A minimum slope requirement of ¼" (6 mm) per foot of rise is recommended.
- C. Apply over clean, dry, dust and debris-free substrates. When fully bonding, prime concrete decks and required substrates, prior to application with PG 100 Fast-Drying Asphalt Primer, WB-3000 Fast-Drying Water Based Primer or PolyBrite 745 Water Based Primer/Adhesive or applicable ASTM D-41 asphalt primer. Any primed substrate should be fully dry prior to installation. Refer to manufacturer's recommendations.
- D. All substrates shall be designed with proper expansion devices.
- E. Wood decks shall have all joints cross blocked and/or properly supported.
- F. Installation of membrane should not adversely affect the ventilation of existing construction.

Application of Self-Adhered Cap Sheet

- A. Start at the low point of the roof.
- B. Unroll the material and allow to relax prior to application.
- C. Align and position membrane into place, following the line of the lowest edge of the roof.
- D. Fold the aligned membrane in half exposing the split release film.
- E. Peel release film at a 45° angle in a constant motion, ensuring to keep weight on the outer edges as you progress.
- F. Position successive rolls using the 5" (13 cm) FASTLap at the endlap and 3" (7.5 cm) SEAllap ULTRA granule free side lap.
- G. Press the membrane into place with firm, even pressure to ensure a watertight seal. Edges or laps to be firmly rolled by hand roller to ensure full adhesion.
- H. After installation of the entire roof surface, roll with a 75 lbs (34 kg) weighted split-face roller. Take care on sloped roofs by securing the roller and applicator with the appropriate safety equipment.
- I. Applications equal to or greater than 1.5" (4 cm) slope per foot of rise, to be back-nailed at the seams with 11 gauge ring shank simplex-type nails at 8" (20 cm) O.C.

Seaming Intersection Treatment – Field, Sequence (T-Joints)

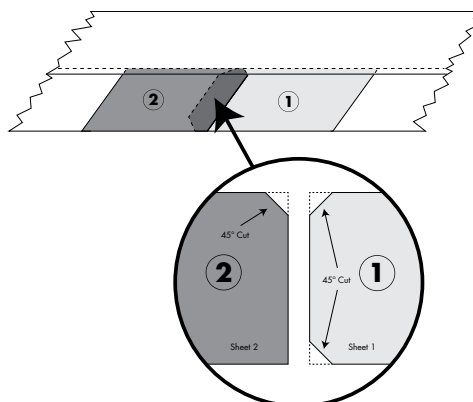

Details, T-joints and flashing may be installed with a hot air welder or with PG 500 Roof Cement or PolyPlus 50 Premium Modified Wet/Dry Cement. Refer to manufacturer's published details for proper design and installation of detail work.

For detailed drawings and recommended installation procedures of typical roof segments, such as drip edge and T-joint conditions, please refer to our website at, www.polyglass.us.

- A. Sheet 1 is applied to substrate.
- B. Cut off the top and bottom corners of the membrane at 45° angles (Sheet 1).
- C. Sheet 2 is aligned and applied to substrate, over lapping sheet 1 by a minimum of 5".
- D. Cut off the top corner of the membrane at a 45° angle (Sheet 2).
- E. Sheet 3 is applied to substrate.
- F. Heat weld or apply PolyPlus® 50 Premium Modified Wet/Dry Cement at the intersection of all 3 sheets, the "T-joint".
- G. Top sheet is carefully rolled at joint.

4.2 Polyglass APP & SBS Heat-Welded Membranes

Application of Heat-Welded Base/Interply Sheets

Polyglass APP or SBS heat-welded base or interply sheet membranes are intended to be used as a base or interply sheet in new or re-roof applications. Polyglass APP or SBS base or interply sheets may be applied directly to non-combustible substrates and require the installation of a compatible granulated cap sheet or approved roof coating to complete the roofing system.

- A. Apply over clean, dry, dust and debris-free substrates. Prime concrete decks and required substrates prior to application with PG 100 Fast-Drying Asphalt Primer and allow to dry. Consult Polyglass Technical Services if alternate primer is allowed.
- B. When re-roofing, remove all prior roofing materials down to a clean debris-free substrate and properly close-off all abandoned roof penetrations.
- C. Concrete or steel decks shall be designed with proper expansion devices.
- D. Wood decks shall have all joints blocked and properly supported.
- E. Ensure the fire rating of the assembly over any combustible substrate.

General Requirements and Design Criteria

- F. Ensure the installation of the membrane does not prevent the ventilation of existing construction.
- G. Do not apply over shingles or any granulated surface.
- H. While installing Polyglass APP or SBS heat-welded base or interply sheet membranes:
 1. Start at the low point of the roof.
 2. Unroll the material and allow to relax.
 3. Install with traditional heat-welding roofing techniques ensuring proper heating of the roofing material as not to expose the reinforcement.
 4. Do not heat the substrate. Do not overheat to expose or compromise the reinforcement.
 5. Position successive rolls providing a minimum 6" (15 cm) end lap and 3" (7.5 cm) side lap. Asphalt bleed out shall be 1/4"–3/8" (6 mm–10 mm) on all seams.
 6. It is recommended that laps shall be rolled with a 6" (15 cm) wide roller immediately after heat welding.
- I. Details and flashing may be installed using Polyglass APP or SBS heat-welded base or interply sheet membranes with heat-welding techniques. Do not use cold adhesives or hot asphalt. Check project details for proper installation requirements.

Application of Heat-Welded Cap Sheet

Polyglass APP or SBS heat-welded cap sheet membranes are intended to be used as the primary weathering surface in new and re-roof applications. Polyglass APP or SBS heat-welded cap sheet membranes are to be applied as the uppermost layer of a multi-ply roof system over a compatible Polyglass base and/or interply sheet. Polyglass APP or SBS heat-welded cap sheet membranes may be applied directly to certain noncombustible substrates.

- A. Apply over clean, dry, dust and debris-free substrates. Prime concrete decks and required substrates prior to application with PG 100 Fast-Drying Asphalt Primer and allow to dry. Consult Polyglass Technical Services if alternate primer is allowed.
- B. When re-roofing, remove all prior roofing materials down to a clean, dust free substrate. Remove unused or abandoned through-roof penetrations.
- C. All substrates shall be designed with proper expansion devices.
- D. Wood decks shall have all joints cross blocked and/or properly supported.
- E. Installation of the membrane should not adversely affect the ventilation of existing construction.
- F. Do not apply directly to existing shingles or other unacceptable roof coverings.
- G. While installing Polyglass APP or SBS heat-welded cap sheet membranes:
 1. Start at the lowest point of the roof.
 2. Unroll the material and allow it to relax as membrane is positioned prior to installation.
 3. Install with traditional heat-welding roofing techniques ensuring proper heating of the roofing material.
 4. Do not overheat to expose or compromise the reinforcement.
 5. Position successive rolls using the 5" (13 cm) FASTLap at the end of the rolls, where applicable (only premium Polyglass membranes have FASTLap), or 6" on granulated endlaps.

6. Bleed out of asphalt when heat welding the seam should be 1/8"–1/4" (3 mm–6 mm) (typical all seams). Warm/pliable bleed out may be covered by loose granules for enhanced aesthetics.
7. Laps may be lightly rolled with a 4"–6" (10 cm–15 cm) wide roller to ensure lap is fused.

- H. Details and flashings may be installed using heat-welding techniques. Do not adhere using cold adhesives or hot asphalt. Refer to manufacturer's published details for proper design and installation of detail work.

4.3 Polyglass SBS Hot Mop Membranes

Application of Hot Mop Base and Cap Sheets

- A. The first roll of Polyglass SBS Base or Cap sheet shall be set and unrolled completely. It shall then be re-rolled and installed to the initial alignment set.
- B. Following rolls shall be unrolled approximately 6' (2 m) (or half roll length if desired) to align sheets to the lap lines (or selvage edges).
- C. The sheets shall then be set in a solid mopping of approved asphalt (see below) depending upon variables such as slope and substrate using approximately 25 lbs (11 kg) per 100 ft² (9.2 m²).
- D. Where asphalt is required by specification, Polyglass recommends the use of ASTM D312 Type III or Type IV Asphalt commensurate with roof slope, installed as follows.
 1. Asphalt should be applied at the proper EVT (Equiviscous Temperature), as recommended by the asphalt supplier/manufacturer, and the NRCA manual (Technical Bulletin #2). Polyglass cannot be held responsible for any damages which may occur should the applicator or specifier, require a method of hot mopping other than those recommended by Polyglass. Furthermore, since the decision is something the applicator must determine based upon ambient and job-site conditions it is the applicator's sole responsibility and Polyglass will not be responsible for any deviations from recommended procedures.
 2. Mopping temperature should be maintained at a minimum 400°F (204°C) (with a target of 425°F (218°C)) at the point of application.
 3. If minimum asphalt temperature of 400°F (204°C) cannot be maintained at the point of application, work should be discontinued.
 4. Asphalt shall be applied at the recommended minimum rate (25 lbs (11 kg) per ply, per square) in an even, uniform method without interruptions or voids.
 5. Mopping should not progress more than 5'–7' (1.5 m–2 m) in front of the roll at any time.
 6. During cold temperature application, insulated equipment is recommended for maintaining minimum acceptable temperatures. Asphalt shall be applied no more than 4' (1.2 m) ahead of the membrane roll.
 7. Brooming of felts is recommended to ensure 100% bonding in the asphalt.

General Requirements and Design Criteria

8. Never overheat asphalt to compensate for cold weather conditions.
 9. Areas of asphalt “bleed-out” at seam edges and details (such as curb or flashing corners, etc.) of granular membrane should be treated by sprinkling additional loose granules (available from Polyglass) into the fresh, hot asphalt. Areas missed may require patching with a new piece of membrane.
 10. For a short time after installation, foot traffic on the sheets should be kept to a minimum in order to avoid unnecessary damage to the membrane.
- G. Apply only when ambient temperatures are 35°F (1.5°C) and rising. Cold weather will cause product to stiffen, making application difficult.
 - H. Do not apply if inclement weather is expected within 24 hours.
 - I. Do not heat outside of container or attempt to thin this product. Not recommended for application on substrates that exceed 140°F (60°C).
 - J. Close air intakes on roof until solvents dissipate. Solvent vapor can penetrate porous substrates. Make sure there is proper outside ventilation for the underside of this type of roof deck.

4.4 Polyglass SBS Cold Applied Membranes

Application of Cold Applied Base and Cap Sheets

Install base and interply sheet in a full coating of approved cold adhesive in accordance with Polyglass PolyPlus® 35 Premium Modified Bitumen Adhesive or PG 350 Modified Bitumen Adhesive application instructions of acceptable adhesive manufacturer’s recommendations and installation instructions.

Surface Preparation:

- A. Surfaces to receive coating must be clean, dry and free from any foreign matter such as dirt, oils, grease or other debris that could inhibit the adhesion capabilities of the newly installed products. Priming is recommended when adhering to questionable conditions.
- B. On existing roofs, inspect roof substrate condition. Blisters, buckles, and raised edges should be cut out and repaired for a smooth surface.
- C. Check all flashings, edges, drains, valleys and vents and repair as needed.
- D. Do not use on wet or damp surfaces, directly over wood or on surfaces previously covered with coal tar-based products.

Application:

- A. Stir well prior to application.
- B. Application Rate: Approximately 1.5–2 gallons (5.7 L–7.6 L) per square when applied to smooth to semi-smooth surfaces. Coverage rate may vary depending on ambient temperature, surface porosity, as well as applicator and/or application technique.
- C. PolyPlus® 35 may be applied by high pressure spray, notched squeegee, or brush application methods.
- D. After Adhesive Application: Apply membrane within 15 minutes of adhesive application. Unroll modified and base sheet rolls and allow them to relax prior to installation. Make sure that membrane is lying flat and making full contact with the adhesive. Roll all side and end laps making sure a sufficient amount of adhesive is applied so that a bead is visible at all lap edges.
- E. Two Layer Application: Install SBS base membrane in adhesive - wait three to seven hours to allow adhesive to set before installing the SBS cap membrane.
- F. Slope Application: The adhesive may be used on various slopes up to 1.5" (4 cm) per foot. Slopes less than or equal to 1.5" (4 cm) per foot may require back-nailing. Please call Polyglass Technical Services should you have any questions on slope application.

Part 5: Slope and Fastening Requirements

- A. Polyglass recommends positive slope to drain criteria (see also drainage section), that the recommendations of the NRCA and ARMA be followed and that roofs be provided with a minimum slope of ¼":12. All ponding water shall dissipate after a period of 48 hours.
- B. Follow the requirements of the insulation manufacturer for fastening or attachment of the insulation system. Roof Insulation Boards shall be attached with an Factory Mutual (FM) Approved fastening pattern or attachment methods for the wind loads expected. The fastening may vary from manufacturer to manufacturer. Consult the latest Factory Mutual (FM) Approval Guide or contact Polyglass Technical Services for assistance.
- C. For typical fastening requirements for Base Sheets, consult the latest Factory Mutual (FM) Approval Guide or contact Polyglass Technical Services for assistance.
- D. Membrane Back-Nailing Requirements are provided in Table 1.
- E. On non-nailable decks, nailers (adequately secured to the deck) may be required at specific spacing to allow for back nailing of membranes. In such cases the membrane is to be fastened into the nailers with suitable fasteners.

General Requirements and Design Criteria

	1/4" – 1/2"	> 1/2" – 1 1/2" (see Footnote 1)	1 1/2" – 3" (see Footnote 1)	> 3" – 6" (see Footnote 1)
SBS MEMBRANES SELF-ADHERED MEMBRANES POLYSTICK UNDERLAYMENTS	NO BACK NAILING REQUIRED	WOOD NAILER INSTALLED AT RIDGE, EVE AND 32' CENTERS	WOOD NAILER INSTALLED AT RIDGE, EVE AND 16' CENTERS	WOOD NAILER INSTALLED AT RIDGE, EVE AND 12' CENTERS
APP MEMBRANES ALL SMOOTH AND GRANULATED, POLYESTER OR POLYESTER/GLASS COMBINED PRODUCTS	NO BACK NAILING REQUIRED	> 3" – 6" (see Footnote 1)	> 6" (see Footnote 1)	
		WOOD NAILER INSTALLED AT RIDGE, EVE AND 16' CENTERS	WOOD NAILER INSTALLED AT RIDGE, EVE AND 16' CENTERS	

¹NOTE: For SBS, Self-Adhered and Polystick® membranes on slopes > 6°, contact Polyglass Technical Services Department.
Nailers matching the height of the insulation are to be installed at the ridge, eve and:
(1) at 32', 16', 12' or 10' centers, parallel (strap) to the slope, as delineated above. Modified sheets are cut to 10', 12' or 16' lengths and back nailed at the end lap into the nailers using Polyglass approved Fasteners and Plates at a spacing of 4" on center staggered (max).
* Applicable APP membranes heat-welded directly over mechanically attached base sheet, or other acceptable substrate. Where APP membranes are applied over mopped or cold applied base sheets SBS requirements apply.

Part 6: Re-Cover or Re-Roofing

Polyglass products are suitable for many re-cover roofing applications. While it is necessary to completely remove any areas of decking, roof covering and insulation that are badly deteriorated and/or moisture laden, some existing roofs may be suitable for re-covering without complete removal, provided they are adequately prepared. All re-roofing projects must be considered unique and each should be assessed on an individual basis. Some general procedures are recommended in considering any project.

NOTE: Analysis of the existing conditions (such as drainage, existing moisture, deck & structural integrity, etc.) is the responsibility of the building owner or the design professional. The determination of need for a vapor retarder is the sole decision of a design professional i.e. Registered Professional Engineer or Architect, or Registered Roof Consultant.

Polyglass recommends that a professional moisture survey and analysis be carried out to determine the existing moisture content of the roof, just prior to commencing the re-roof or re-cover work. To qualify for certain system guarantees, which may be obtainable through Polyglass Registered Contractors, the need for an infrared (IR) scan, or other suitable survey may be mandatory for obtaining a guarantee.

NOTE: Where the existing roofing system (all existing waterproofing and insulation materials, including any vapor retarders) is to be removed down to the deck, AND where it is determined (by the owner, design professional, architect or engineer) that the existing deck is suitable for applying a new roofing system, the requirements for new roofing may be applicable. Where existing roofing materials are to be left in place, the following requirements are to be adhered to. The following recommendations provide some guidelines for assessment of the existing roof system to determine the appropriate Polyglass re-cover/re-roof system:

- A. Evaluate existing roof conditions including interior and exterior surveys. Locate points of interior leakage, condition of underside of deck, and areas where moisture may be present in the system/insulation.
 - B. The adequacy needs for a vapor retarder (see section on Vapor Retarders) should be established, by a party other than Polyglass.
 - C. Establish whether the deck is structurally sound and able to accept the imposed weight of a new system.
 - D. Determine whether the method of existing roof attachment is adequate.
 - E. Ensure adequate provision made for clearance (height) of new or existing curbs, counter flashing, walls, etc.
 - F. Determine whether the roof system drains properly and what measures are necessary prior to the re-cover/re-roof operation. Existing deck deflection or ponding water may require upgrading of the drainage provisions, including possible addition of new drains, increased bar joist support, etc.
 - G. Ensure that there is no more than one existing roof covering.
- Once the applicability and practicality of a re-cover/re-roof has been determined, by the building owner or his design professional, and when all preliminary evaluations and necessary adjustments, or allowances, have been made the following preparations must be carried out.

Preparation

The ultimate performance of any re-cover project is the direct result of adequate preparation of the existing roof assembly. The following are the minimum recommendations for a successful re-cover:

- A. Power broom and vacuum all surfaces to remove loose aggregate.
- B. All wet or deteriorated areas of membrane, insulation or decking, components, blisters, splits, and surface irregularities shall be removed and patched to create a stable, smooth and even surface.

General Requirements and Design Criteria

- C. Remove existing roof flashings from curbs and parapet walls down to roof surface.
- D. Remove existing flashings at roof drains and roof penetrations.
- E. Install new wood nailers as necessary to accommodate insulation/recovery board or new nailing patterns.
- F. When mechanically attached, the fastening pattern for the insulation/recovery board shall be as recommended by the specific product manufacturer.
- G. Re-roofing over coal tar pitch generally requires a mechanically attached recovery board or insulation and a base sheet prior to the application of a Polyglass roofing system.

Part 7: Test Approvals and Classifications

Polyglass has an ongoing Code Approvals and Product Compliance Testing program. Polyglass products are widely tested and approved in accordance with the requirements of ASTM and a variety of international approval bodies and testing laboratories in accordance with many internationally recognized standards. For specific details please contact Polyglass or consult the latest published listings of the various code/approval bodies.

Testing is carried out by:

- Underwriter's Laboratories, LLC (UL)
- Factory Mutual Approvals (FM)
- Miami-Dade County Building Code Compliance (NOA)
- Florida Building Code (FBC)
- International Code Council (ICC)
- Texas Department of Insurance (TDI)
- Cool Roof Ratings Council (CRRC)
- Canadian Standards Association (CSA)
- Canadian General Standards Board (CGSB)

Part 8: Polyglass Tiered Contractor Program

Polyglass maintains a roster of Roofing Contractors (Registered, Preferred and Quantum) who install and repair Polyglass roofing systems. Polyglass Roofing Contractors are those contractors who are eligible for Limited Material, Labor and Material, and Fully System Warranties, provided the installation complies with current Polyglass Details and Guide Specifications.

The Polyglass contractor program is a three-tiered program that rewards contractors for quality Polyglass roof system installations. Designed to recognize the contractor for their commitment to excellence, each tier provides unique benefits. The three tiers are:

- Registered Contractor
- Preferred Contractor
- Quantum Contractor

Polyglass Roofing Applicators are not agents or representatives of Polyglass. They are, however, independent applicators who have expressed an interest in Polyglass and have met the qualifications required by Polyglass. For specific applicators in your area, or to receive information on becoming a Polyglass Applicator, please contact a Polyglass Sales Representative or visit our website www.polyglass.us.

Part 9: Polyglass Warranty Program

Polyglass offers no-cost Limited Material and Labor and Material Warranties. These Warranties protect the owner from leaks as a result of defective material. The length of these Warranties can vary from 10 to 30 years, depending on the specific system and materials installed.

For a fee, Polyglass offers NDL (No Dollar Limit) Full System Warranties. These warranties protect the owner from leaks caused by defective material and workmanship (provided the system has been correctly installed by a Polyglass Preferred or Quantum Applicator. Full Systems warranties provide protection to the owner by covering all Polyglass products in the assembly, not just the roofing membrane. Full Systems warranties provide the owner with extensive protection. The systems are limited to materials supplied by Polyglass, and certain requirements, formalities of application and acceptance are required, PRIOR to the installation work.

For specific Warranty Fees and Systems, contact your Polyglass Sales Representative.

Polyglass Reserves the right not to issue the requested Warranty if the proper Guidelines of Registration have not been followed, or if the system does not meet the minimum requirements required for the desired Warranty.

Guide Specifications

2-Ply Systems



2-Ply Self-Adhered

1. **Cap Sheet:** Polyflex® SA P, Elastoflex SA P or Polyfresko® G SA
2. **Base Sheet:** Elastoflex SA V or SA V PLUS
3. **Roof Deck:** Plywood

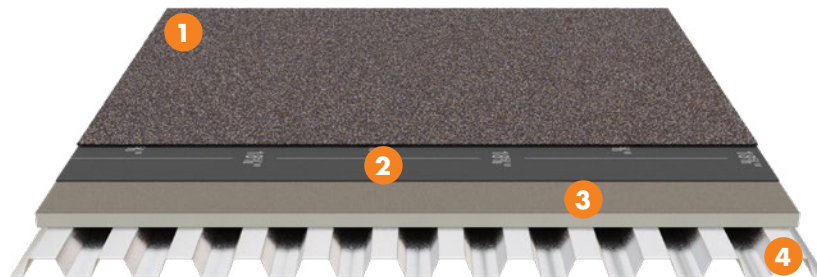

2-Ply Self-Adhered

1. **Cap Sheet:** Polyflex® SA P, Elastoflex SA P or Polyfresko® G SA
2. **Base Sheet:** Elastoflex SA V or SA V PLUS
3. **Insulation:** Polyglass Polytherm® ISO
4. **Roof Deck:** Heavy Gauge Steel, Structural Concrete or Plywood

Guide Specifications

2-Ply Systems

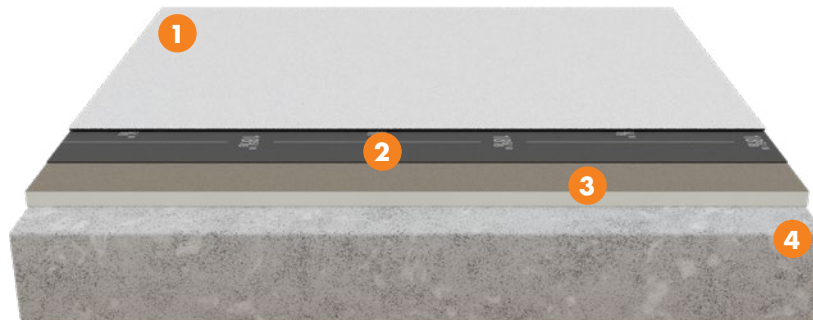

2-Ply Stick 1-Torch 1

1. **Cap Sheet:** Polyflex® G, Elastoflex S6 G or Polyfresko® G
2. **Base Sheet:** Elastoflex SA V or SA V PLUS or Elastobase® SA
3. **Insulation:** Polyglass Polytherm® ISO
4. **Roof Deck:** Heavy Gauge Steel or Structural Concrete

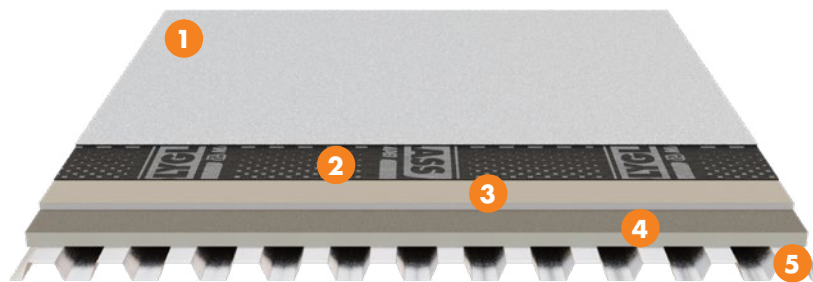

2-Ply Heat Welded APP

1. **Cap Sheet:** Polyflex® G or Polyfresko® G
2. **Base Sheet:** Polyglass Base or Polyflex®
3. **Coverboard:** (by others)
4. **Insulation:** Polyglass Polytherm® ISO
5. **Roof Deck:** Heavy Gauge Steel or Structural Concrete

Guide Specifications

2-Ply Systems

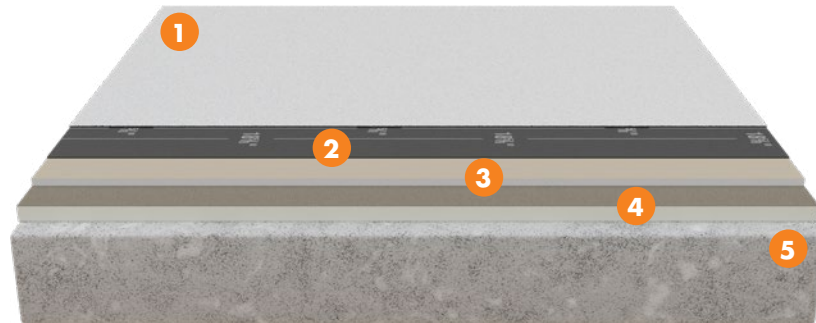

2-Ply Heat Welded SBS

1. **Cap Sheet:** Elastoflex S6 G, Elastoshield® TS G or Polyfresko® G SBS
2. **Base Sheet:** Elastoflex S6 or Elastoshield® TS
3. **Coverboard:** (by others)
4. **Insulation:** Polyglass Polytherm® ISO
5. **Roof Deck:** Heavy Gauge Steel or Structural Concrete



2-Ply Lightweight Heat Welded

1. **Cap Sheet:** Polyflex® G, Elastoflex S6 G or Polyfresko® G
2. **Interply Sheet:** Polyflex® or Elastoflex S6
3. **Base Sheet:** Elastobase® or Elastovent® (mechanically attached)
4. **Roof Deck:** Lightweight Insulation Concrete (LWIC of approved type)

Guide Specifications

2-Ply Systems

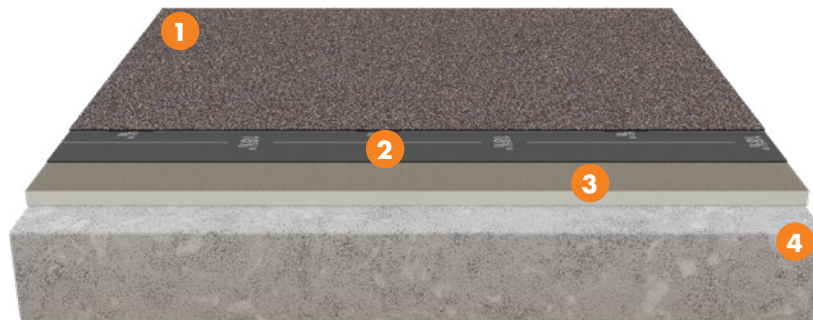

2-Ply Hot Mop

1. **Cap Sheet:** Elastoflex S6 G, Elastoflex S6 G HP or Elastoshield® TS G
2. **Base Sheet:** Elastobase® or Elastoflex V or Elastoshield® TS
3. **Insulation:** Polyglass Polytherm® ISO (optional)
4. **Roof Deck:** Structural Concrete



2-Ply Velociflex System

1. **Cap Sheet – Heat Welded**:** Polyfresko® G/G SBS, Elastoflex S6 G/S6 G HP, Elastoshield TS G, or Polyflex® G/G HP
2. **Base Sheet – Mechanically Fastened (seam is heat fused):** Elastoflex S6, Elastoflex S6 HP** or Polyflex®
3. **Insulation:** Polyglass Polytherm® ISO
4. **Roof Deck:** Heavy Gauge Steel or Structural Concrete

Note: Wind Uplift ratings determined by fastener pattern. Contact Polyglass Technical Support for full specifications.
**Velociflex Systems may also incorporate cold applied bonding for cap sheet membranes.

Guide Specifications

3-Ply Systems

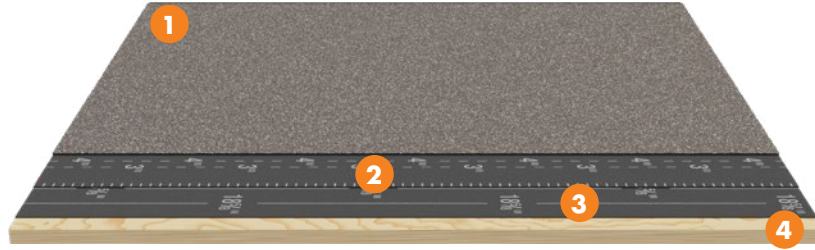

3-Ply Self-Adhered

- 1. **Cap Sheet:** Polyflex® SA P, Elastoflex SA P or Polyfresko® G SA
- 2. **Interply Sheet:** Elastoflex SA V or SA V PLUS
- 3. **Base Sheet:** Elastoflex SA V or SA V PLUS
- 4. **Roof Deck:** Plywood

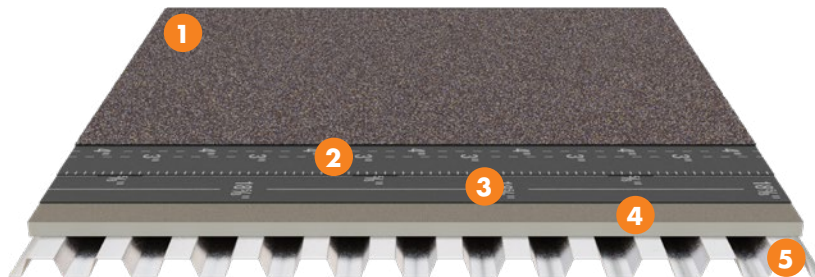

3-Ply Self-Adhered

- 1. **Cap Sheet:** Polyflex® SA P, Elastoflex SA P or Polyfresko® G SA
- 2. **Interply Sheet:** Elastoflex SA V or SA V PLUS
- 3. **Base Sheet:** Elastoflex SA V or SA V PLUS
- 4. **Insulation:** Polyglass Polytherm® ISO
- 5. **Roof Deck:** Heavy Gauge Steel, Structural Concrete or Plywood

Guide Specifications

3-Ply Systems

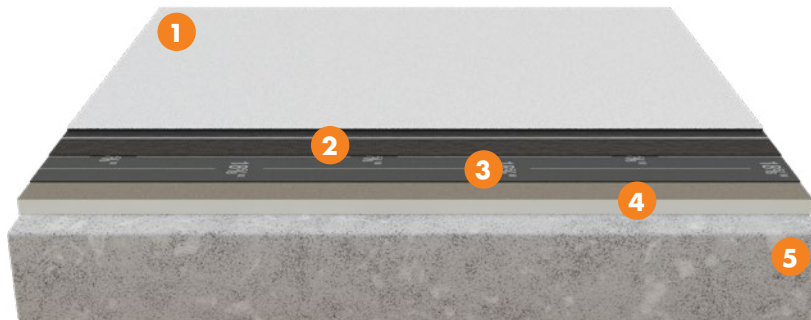

3-Ply Stick 2-Torch 1 System

1. **Cap Sheet:** Polyflex® G, Elastoflex S6 G or Polyfresko® G
2. **Interply Sheet:** Elastoflex SA V or SA V PLUS or Polyflex®
3. **Base Sheet:** Elastoflex SA V or SA V PLUS
4. **Insulation:** Polyglass Polytherm® ISO
5. **Roof Deck:** Heavy Gauge Steel or Structural Concrete

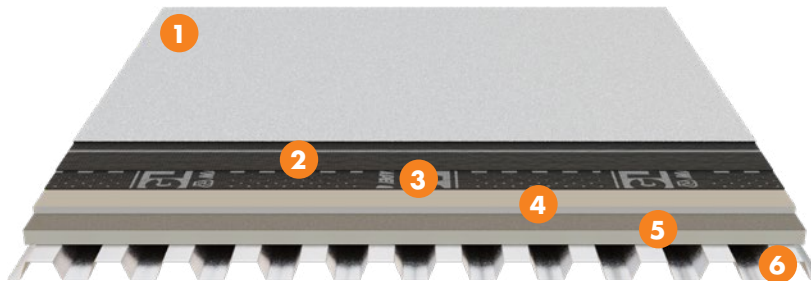

3-Ply Heat Welded APP

1. **Cap Sheet:** Polyflex® G or Polyfresko® G
2. **Interply Sheet:** Polyglass Base or Polyflex®
3. **Base Sheet:** Polyglass Base or Polyflex®
4. **Coverboard:** (by others)
5. **Insulation:** Polyglass Polytherm® ISO
6. **Roof Deck:** Heavy Gauge Steel or Structural Concrete

Guide Specifications

3-Ply Systems

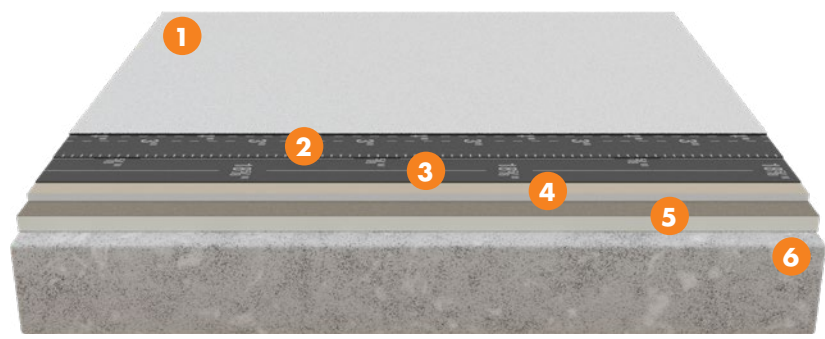

3-Ply Heat Welded SBS

- 1. **Cap Sheet:** Elastoflex S6 G or Elastoshield® TS G
- 2. **Interply Sheet:** Elastoflex S6 or Elastoshield® TS
- 3. **Base Sheet:** Elastoflex S6 or Elastoshield® TS
- 4. **Coverboard:** (by others)
- 5. **Insulation:** Polyglass Polytherm® ISO
- 6. **Roof Deck:** Heavy Gauge Steel or Structural Concrete

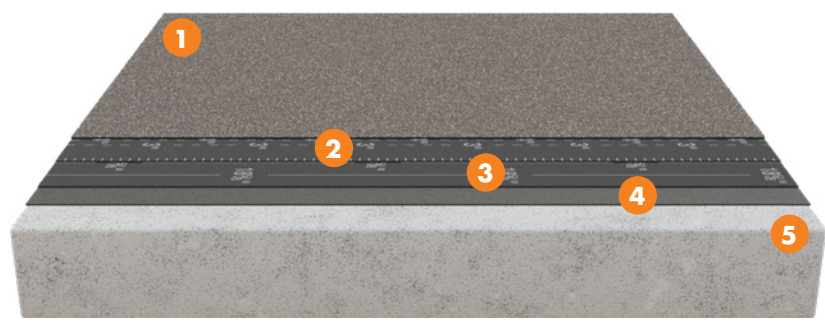

3-Ply Lightweight Heat Welded

- 1. **Cap Sheet:** Polyflex® G, Elastoflex S6 G or Polyfresko® G
- 2. **Interply Sheet:** Polyflex® or Elastoflex S6
- 3. **Base Sheet:** Polyflex® or Elastoflex S6
- 4. **Base Sheet:** Elastobase® or Elastovent™ (mechanically attached)
- 5. **Roof Deck:** Lightweight Insulation Concrete (LWIC of approved type)

Guide Specifications

3-Ply Systems

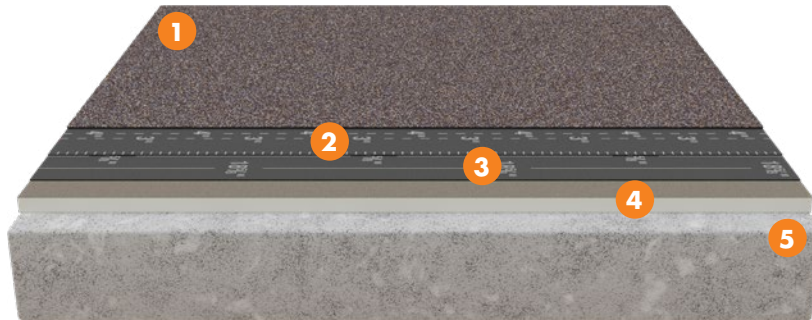

3-Ply Hot Mop

1. **Cap Sheet:** Elastoflex S6 G, Elastoflex S6 G HP or Elastoshield® TS G
2. **Interply Sheet:** Elastobase® or Elastoflex V or Elastoshield® TS
3. **Base Sheet:** Elastobase® or Elastoflex V or Elastoshield® TS
4. **Insulation:** Polyglass Polytherm® ISO (optional)
5. **Roof Deck:** Structural Concrete



Scan to view Specifications online

Roofing Details

LIQUID-APPLIED DRAIN DETAIL (Typical) – PG-LF-DRN-01

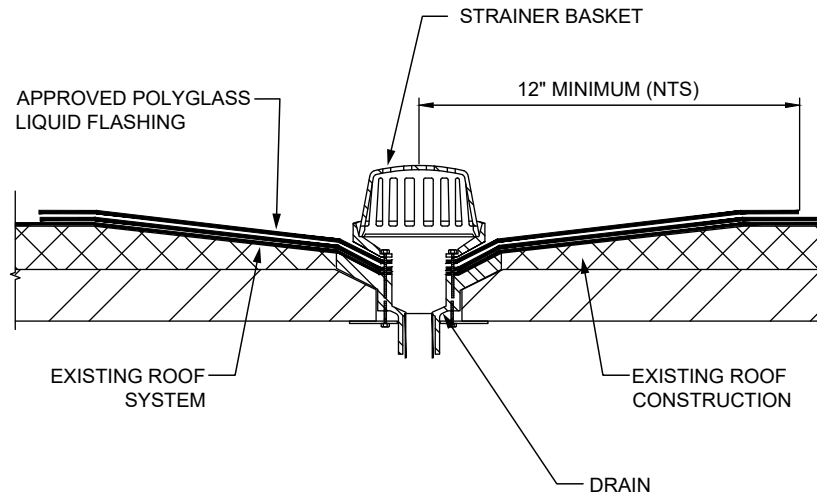

GENERAL NOTATIONS:

- Wood blocking may be slotted for venting of wet-fill decks or other applicable constructions.
- Wood blocking may be required at drain, depending on insulation thickness and type (not shown for clarity).
- Cleaning and Preparation - Clean and prepare the surface by brooming mild detergent & water rinse or as required to remove any conditions that could adversely affect the adhesion of primers and liquid materials.
- Surfaces to receive Polyglass Liquid Flashing System may need to be primed, depending on the surface.
- Polyglass Liquid Flashing System consists one of the following; PolyFlash 1C Base Coat, embed Polybrite Fabric, covered with PolyFlash 1C Surface Coat or Polyglass PMMA Flashing Base Coat, embed Polyglass PMMA Polyester, covered with Polyglass PMMA Flashing Surface Coat.
- Illustration and notations intended for generalized application only. Please refer to Product Data Sheets for additional information.

POLYFLASH 1C PIPE PENETRATION DETAIL (Typical) – PG-LF-PEN-01

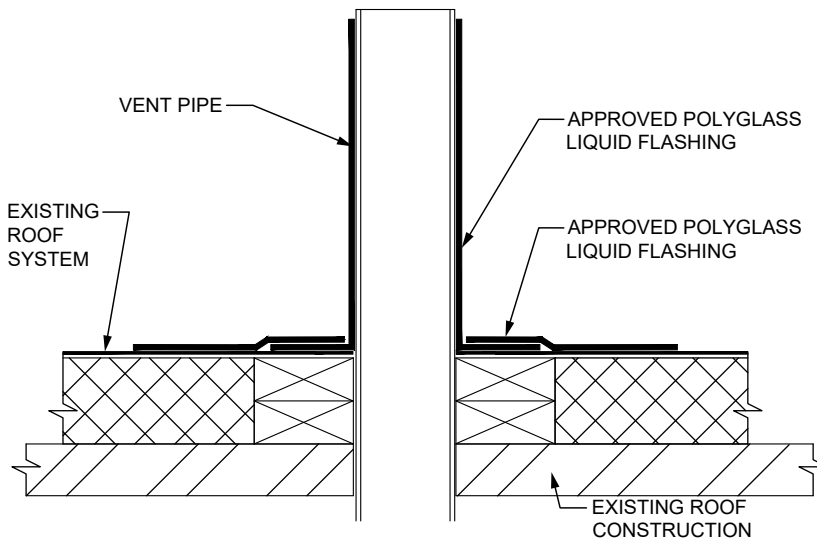

GENERAL NOTATIONS:

- Wood blocking may be slotted for venting of wet-fill decks or other applicable constructions.
- Wood blocking may be required at drain, depending on insulation thickness and type (not shown for clarity).
- Cleaning and Preparation - Clean and prepare the surface by brooming mild detergent & water rinse or as required to remove any conditions that could adversely affect the adhesion of primers and liquid materials.
- Surfaces to receive Polyglass Liquid Flashing System may need to be primed, depending on the surface.
- Polybrite Liquid Flashing System consists of PolyFlash 1C Base Coat, embed Polybrite Reinforcing Polyester, covered with PolyFlash 1C Top Coat.
- Illustration and notations intended for generalized application only. Please refer to Product Data Sheets for additional information.

POLYFLASH 1C FABRICATED CURB FLASHING DETAIL (Typical) – PG-LF-PEN-02

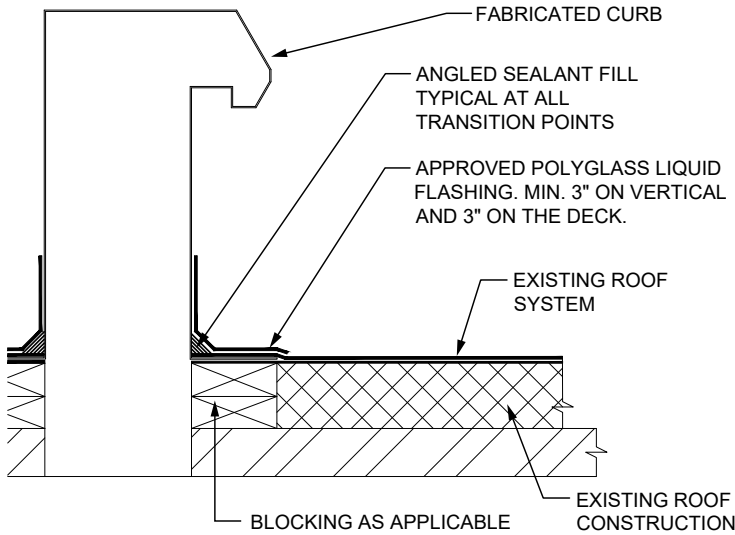

GENERAL NOTATIONS:

- Wood blocking may be slotted for venting of wet-fill decks or other applicable constructions.
- Cleaning and Preparation - Clean and prepare the surface by brooming mild detergent & water rinse or as required to remove any conditions that could adversely affect the adhesion of primers and liquid materials.
- Surfaces to receive Polyglass Liquid Flashing System may need to be primed, depending on the surface.
- Polyglass Liquid Flashing System consists of PolyFlash 1C Base Coat, embed Polybrite Reinforcing Polyester, covered with PolyFlash 1C Top Coat.
- Illustration and notations intended for generalized application only. Please refer to Product Data Sheets for additional information.

POLYFLASH 1C FLASHING DETAIL (Typical) – PG-LF-VERT-01

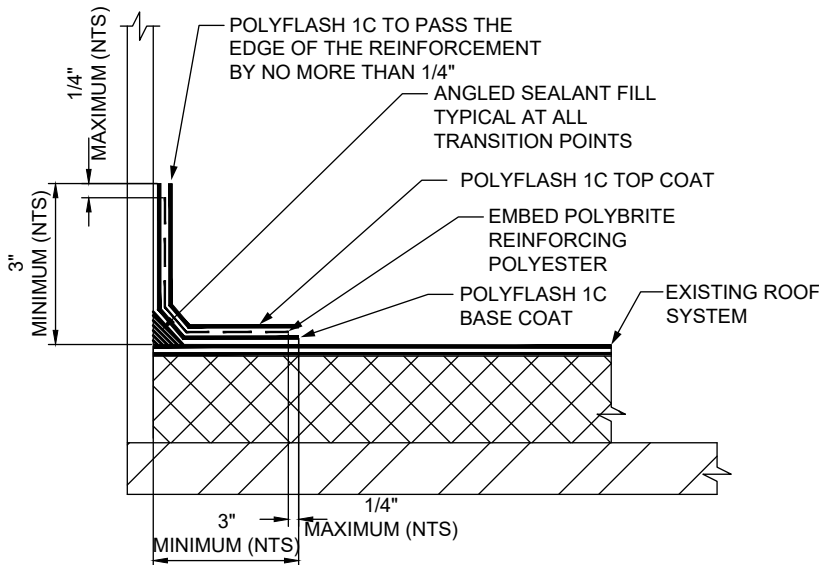

GENERAL NOTATIONS:

- Metal Edge Flashing, Wood Blockings and Attachments shall comply with ANSI/SPRI ES-1.
- Wood blocking may be slotted for venting of wet-fill decks or other applicable constructions.
- Detail only applicable when installing a membrane field wrap application, otherwise use approved metal flashings.
- Cleaning and Preparation - Clean and prepare the surface by brooming mild detergent & water rinse or as required to remove any conditions that could adversely affect the adhesion of primers and liquid materials.
- Surfaces to receive Polyglass Liquid Flashing System may need to be primed, depending on the surface.
- Illustration and notations intended for generalized application only. Please refer to Product Data Sheets for additional information.

Roofing Details

CURB DETAIL (Typical) – PG-LS-CURB-01

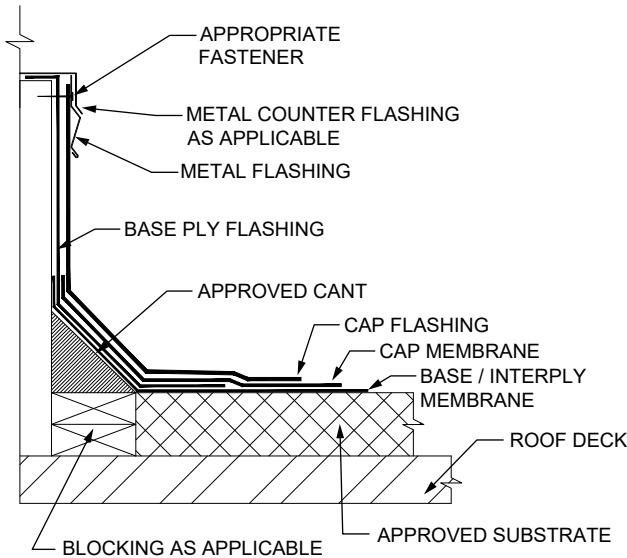

GENERAL NOTATIONS:

- Metal Edge Flashing, Wood Blockings and Attachments shall comply with ANSI/SPRI ES-1.
- Refer to SMACNA recommendations and details regarding metal thickness and cleat requirements. Continuous cleats are recommended at all edges and coping flashings, cleats to be at least one gauge heavier than the edge/coping metal.
- Wood blocking may be slotted for venting of wet-fill decks or other applicable constructions.
- For heat fused membrane applications, set metal flashing onto heated softened membrane.
- Extension of field base/plies 1" min above top of cant, required (not shown for clarity).
- Membrane end laps to be a minimum 6" and fully adhered at all membrane to membrane seams.
- Membrane laps at flanged metal to be 3" minimum and fully bonded to primed metal surface.
- Use only when roof deck is support by the wall.

EQUIPMENT CURB DETAIL (Typical) – PG-LS-CURB-02

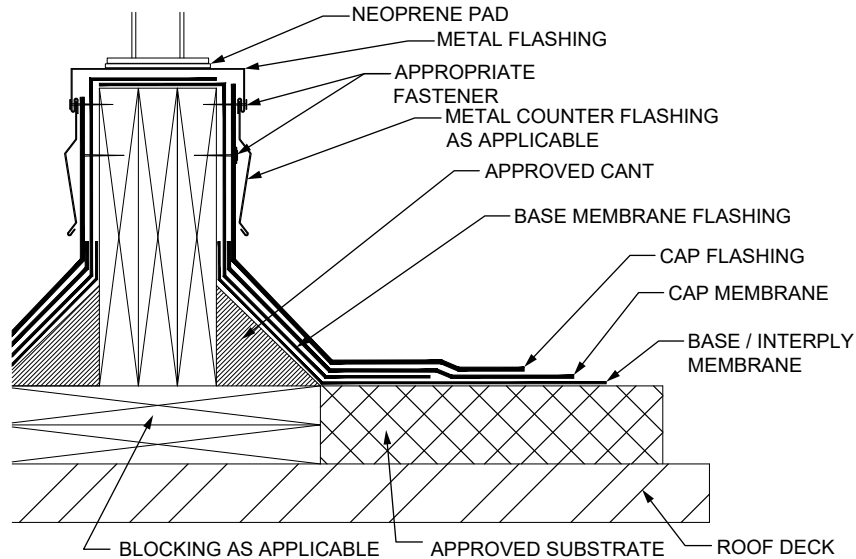

GENERAL NOTATIONS:

- Metal Edge Flashing, Wood Blockings and Attachments shall comply with ANSI/SPRI ES-1.
- Refer to SMACNA recommendations and details regarding metal thickness and cleat requirements. Continuous cleats are recommended at all edges and coping flashings, cleats to be at least one gauge heavier than the edge/coping metal.
- Wood blocking may be slotted for venting of wet-fill decks or other applicable constructions.
- For heat fused membrane applications, set metal flashing onto heated softened membrane.
- Extension of field base/plies 1" min above top of cant, required (not shown for clarity).
- Membrane end laps to be a minimum 6" and fully adhered at all membrane to membrane seams.
- Membrane laps at flanged metal to be 3" minimum and fully bonded to primed metal surface.
- Use only when roof deck is support by the wall.

ROOF DRAIN DETAIL (Typical) – PG-LS-DRN-01

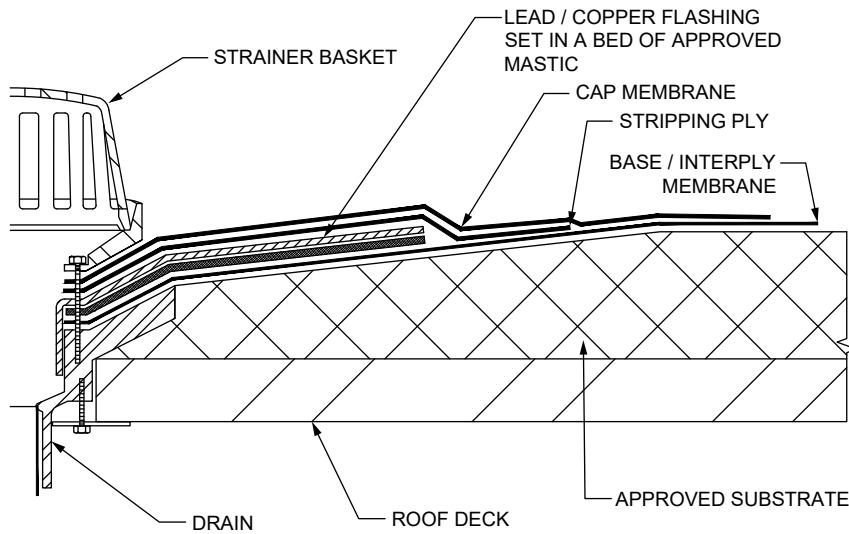

GENERAL NOTATIONS:

- Wood blocking may be slotted for venting of wet-fill decks or other applicable constructions.
- Wood blocking may be required at drain, depending on insulation thickness and type (not shown for clarity).
- For heat fused membrane applications, set metal flashing onto heated softened membrane.
- Membrane end laps to be a minimum 6" and fully adhered at all membrane to membrane seams.
- Drain Installation and re-equipment by others.

EDGE METAL DETAIL (Typical) – PG-LS-EDGE-01

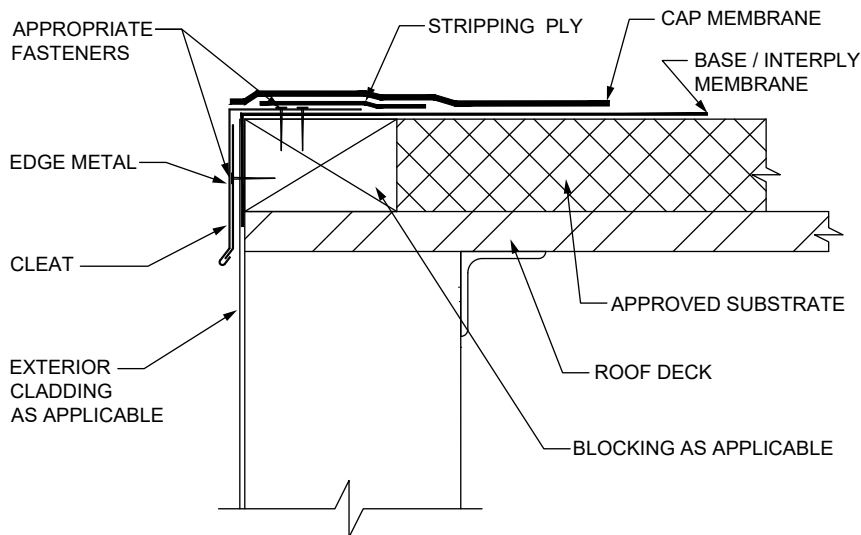

GENERAL NOTATIONS:

- Metal Edge Flashing, Wood Blockings and Attachments shall comply with ANSI/SPRI ES-1.
- Refer to SMACNA recommendations and details regarding metal thickness and cleat requirements. Continuous cleats are recommended at all edges and coping flashings, cleats to be at least one gauge heavier than the edge/coping metal.
- Wood blocking may be slotted for venting of wet-fill decks or other applicable constructions.
- For heat fused membrane applications, set metal flashing onto heated softened membrane.
- Membrane end laps to be a minimum 6" and fully adhered at all membrane to membrane seams.
- Membrane laps at flanged metal to be 3" minimum and fully bonded to primed metal surface.
- Use only when roof deck is support by the wall.
- For Self-Adhered Membranes, in areas prone to freezing conditions, membrane shall be heat welded or sealed with an approved sealant at 90° bend of edge metal.

Roofing Details

RAISED EDGE METAL DETAIL (Typical) – PG-LS-EDGE-02

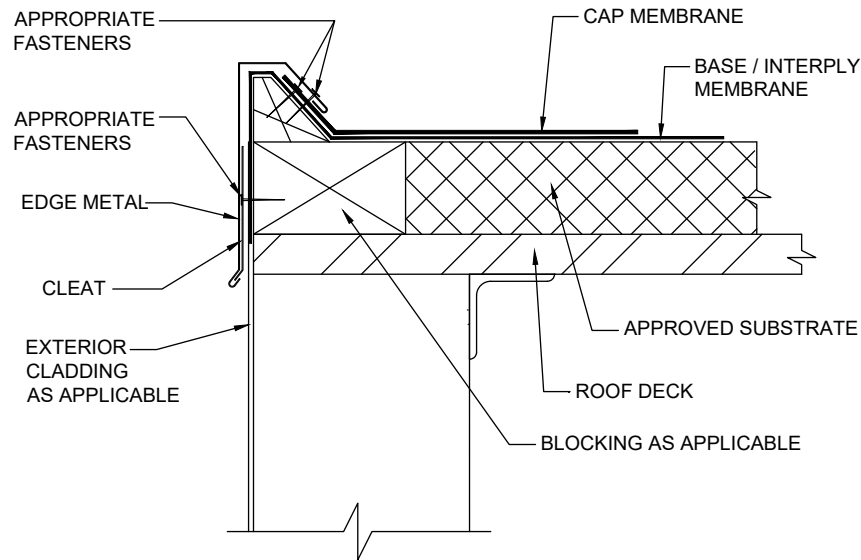

GENERAL NOTATIONS:

- Metal Edge Flashing, Wood Blockings and Attachments shall comply with ANSI/SPRI ES-1.
- Refer to SMACNA recommendations and details regarding metal thickness and cleat requirements. Continuous cleats are recommended at all edges and coping flashings, cleats to be at least one gauge heavier than the edge/coping metal.
- Wood blocking may be slotted for venting of wet-fill decks or other applicable constructions.
- For heat fused membrane applications, set metal flashing onto heated softened membrane.
- Membrane end laps to be a minimum 6" and fully adhered at all membrane to membrane seams.
- Membrane laps at flanged metal to be 3" minimum and fully bonded to primed metal surface.
- Use only when roof deck is support by the wall.

EXPANSION JOINT WITH PRE-MANUFACTURED COVER DETAIL (Typical) – PG-LS-EXP-01

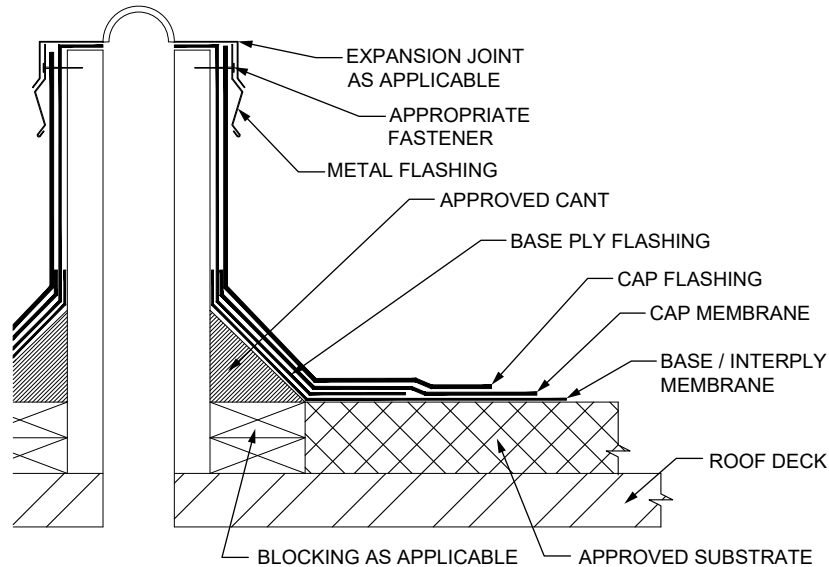

GENERAL NOTATIONS:

- Metal Edge Flashing, Wood Blockings and Attachments shall comply with ANSI/SPRI ES-1.
- Refer to SMACNA recommendations and details regarding metal thickness and cleat requirements. Continuous cleats are recommended at all edges and coping flashings, cleats to be at least one gauge heavier than the edge/coping metal.
- Wood blocking may be slotted for venting of wet-fill decks or other applicable constructions.
- For heat fused membrane applications, set metal flashing onto heated softened membrane.
- Extension of field base/plies 1" min above top of cant, required (not shown for clarity).
- Membrane end laps to be a minimum 6" and fully adhered at all membrane to membrane seams.
- Membrane laps at flanged metal to be 3" minimum and fully bonded to primed metal surface.
- Use only when roof deck is support by the wall.

VENT PIPE FLASHING WITH MEMBRANE SLEEVE DETAIL (Typical) – PG-LS-PEN-01

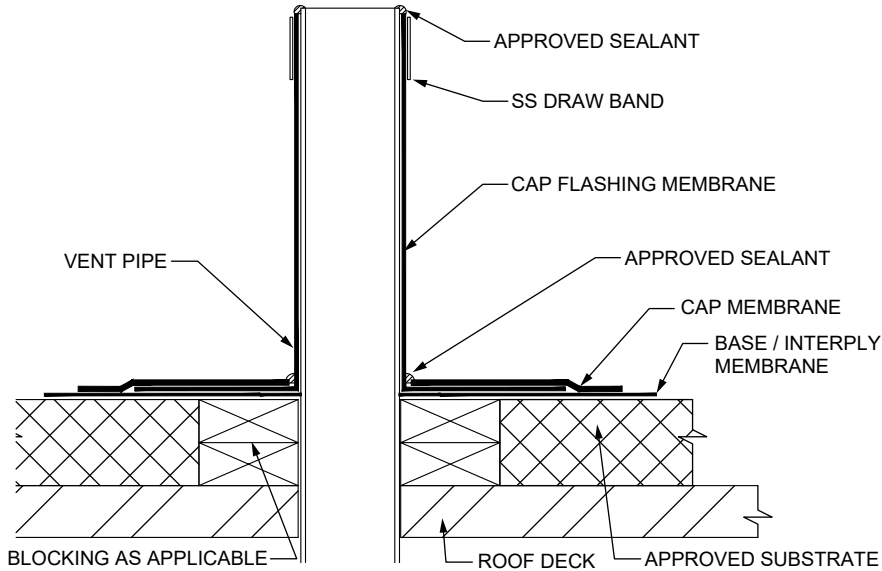

GENERAL NOTATIONS:

- Wood blocking may be slotted for venting of wet-fill decks or other applicable constructions.
- For heat fused membrane applications, set metal flashing onto heated softened membrane.
- Membrane end laps to be a minimum 6" and fully adhered at all membrane to membrane seams.
- Membrane laps at flanged metal to be 3" minimum and fully bonded to primed metal surface.

VENT PIPE FLASHING WITH LEAD SLEEVE DETAIL (Typical) – PG-LS-PEN-02

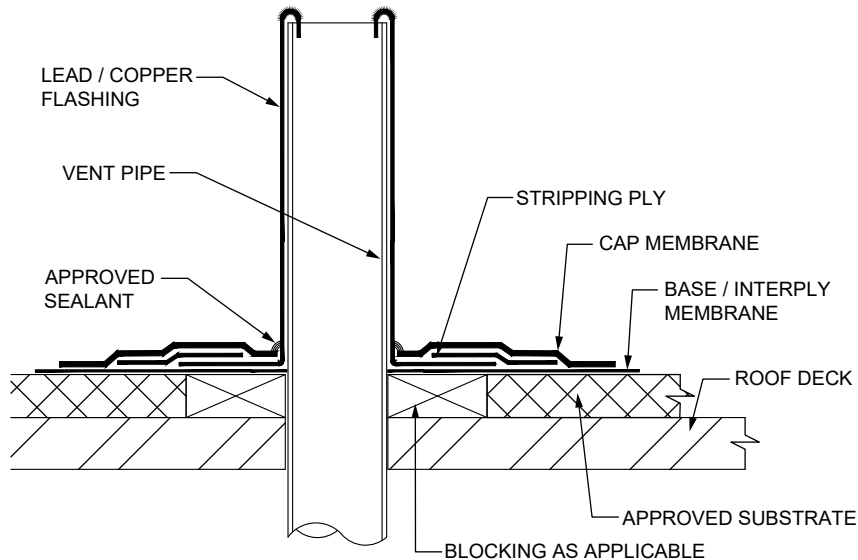

GENERAL NOTATIONS:

- Wood blocking may be slotted for venting of wet-fill decks or other applicable constructions.
- For heat fused membrane applications, set metal flashing onto heated softened membrane.
- Membrane end laps to be a minimum 6" and fully adhered at all membrane to membrane seams.
- Membrane laps at flanged metal to be 3" minimum and fully bonded to primed metal surface.

Roofing Details

VENT PIPE WITH PENETRATION POCKET DETAIL (Typical) – PG-LS-PEN-03

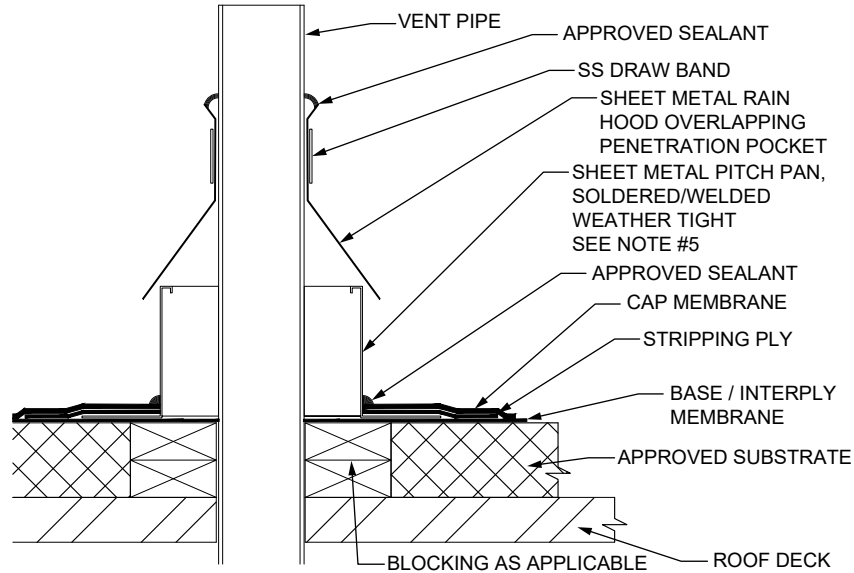

GENERAL NOTATIONS:

- Wood blocking may be slotted for venting of wet-fill decks or other applicable constructions.
- For heat fused membrane applications, set metal flashing onto heated softened membrane.
- Membrane end laps to be a minimum 6" and fully adhered at all membrane to membrane seams.
- Membrane laps at flanged metal to be 3" minimum and fully bonded to primed metal surface.
- Pitch pans filled with approved pourable sealer.

THROUGH WALL SCUPPER DETAIL (Typical) – PG-LS-SCUP-01

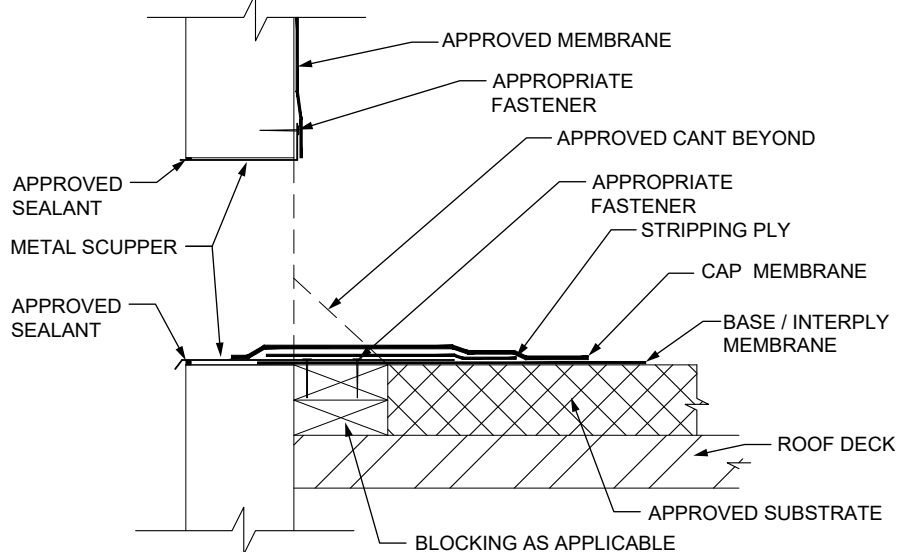

GENERAL NOTATIONS:

- Metal Edge Flashing, Wood Blockings and Attachments shall comply with ANSI/SPRI ES-1.
- Refer to SMACNA recommendations and details regarding metal thickness and cleat requirements. Continuous cleats are recommended at all edges and coping flashings, cleats to be at least one gauge heavier than the edge/coping metal.
- Wood blocking may be slotted for venting of wet-fill decks or other applicable constructions.
- For heat fused membrane applications, set metal flashing onto heated softened membrane.
- Extension of field base/plies 1" min above top of cant, required (not shown for clarity).
- Membrane end laps to be a minimum 6" and fully adhered at all membrane to membrane seams.
- Membrane laps at flanged metal to be 3" minimum and fully bonded to primed metal surface.
- Use only when roof deck is support by the wall.

WALL TO ROOF FLASHING FOR NON-WALL SUPPORTED DECK (Typical) – PG-LS-WALL-01

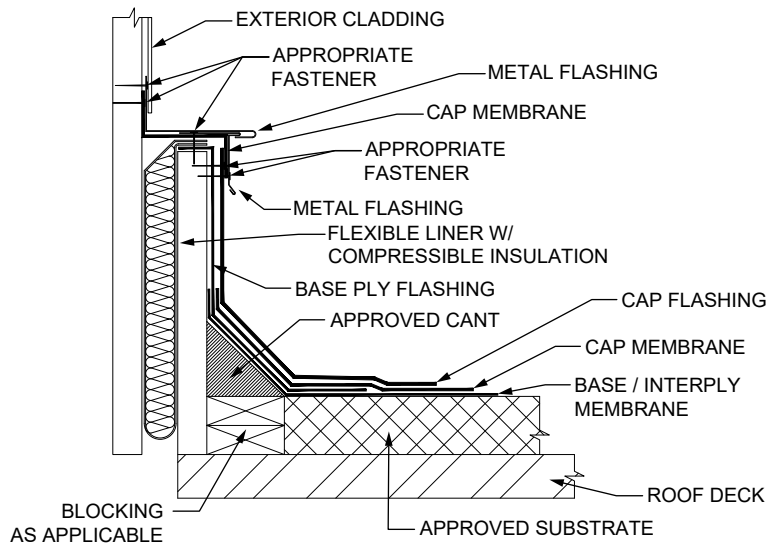

GENERAL NOTATIONS:

- Metal Edge Flashing, Wood Blockings and Attachments shall comply with ANSI/SPRI ES-1.
- Refer to SMACNA recommendations and details regarding metal thickness and cleat requirements. Continuous cleats are recommended at all edges and coping flashings, cleats to be at least one gauge heavier than the edge/coping metal.
- Wood blocking may be slotted for venting of wet-fill decks or other applicable constructions.
- For heat fused membrane applications, set metal flashing onto heated softened membrane.
- Extension of field base/plies 1" min above top of cant, required (not shown for clarity).
- Membrane end laps to be a minimum 6" and fully adhered at all membrane to membrane seams.
- Membrane laps at flanged metal to be 3" minimum and fully bonded to primed metal surface.
- Use only when roof deck is support by the wall.

WALL TO ROOF FLASHING WITH METAL COPING (Typical) – PG-LS-WALL-02

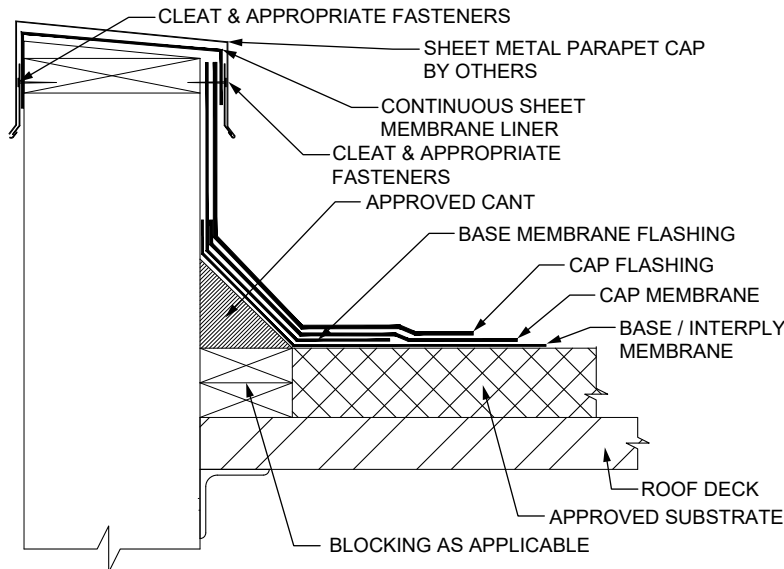

GENERAL NOTATIONS:

- Metal Edge Flashing, Wood Blockings and Attachments shall comply with ANSI/SPRI ES-1.
- Refer to SMACNA recommendations and details regarding metal thickness and cleat requirements. Continuous cleats are recommended at all edges and coping flashings, cleats to be at least one gauge heavier than the edge/coping metal.
- Wood blocking may be slotted for venting of wet-fill decks or other applicable constructions.
- For heat fused membrane applications, set metal flashing onto heated softened membrane.
- Extension of field base/plies 1" min above top of cant, required (not shown for clarity).
- Membrane end laps to be a minimum 6" and fully adhered at all membrane to membrane seams.
- Membrane laps at flanged metal to be 3" minimum and fully bonded to primed metal surface.
- Use only when roof deck is support by the wall.

Roofing Details

OUTSIDE CORNER FLASHING DETAIL (Typical) – PG-LS-WALL-03

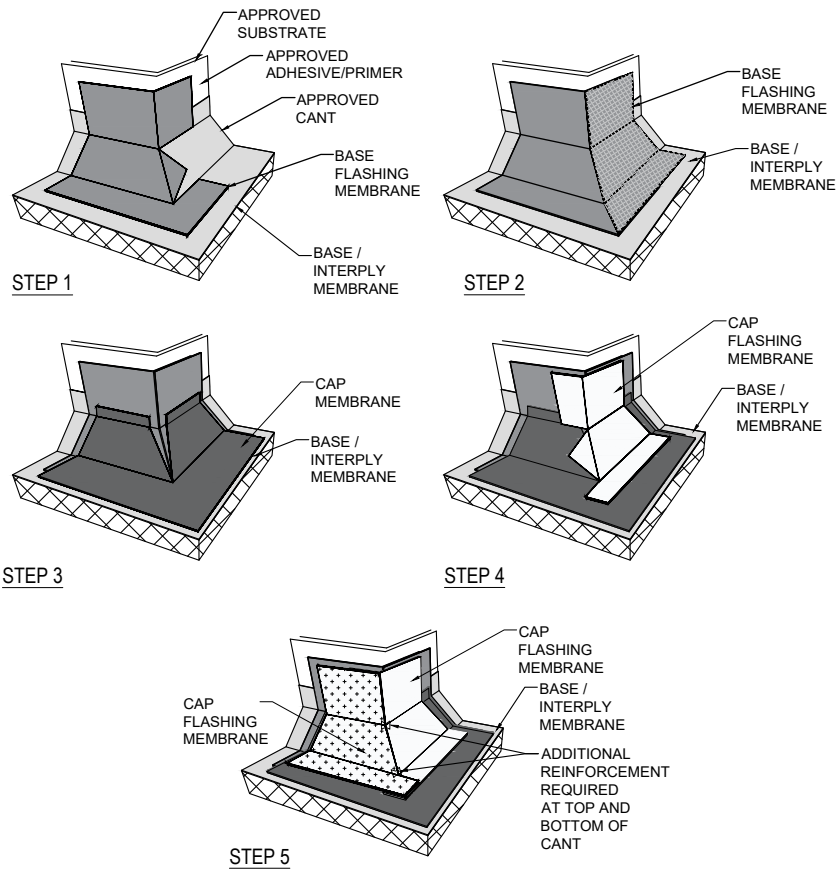

GENERAL NOTATIONS:

- For heat fused membrane applications, set metal flashing onto heated softened membrane.
- Extension of field base/plies 1" min above top of cant, required (not shown for clarity).
- Membrane end laps to be a minimum 6" and fully adhered at all membrane to membrane seams.
- Membrane laps at flanged metal to be 3" minimum and fully bonded to primed metal surface.

INSIDE CORNER FLASHING DETAIL (Typical) – PG-LS-WALL-04

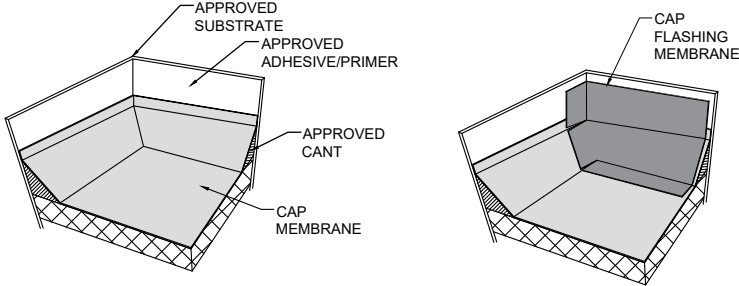

STEP 1

STEP 2

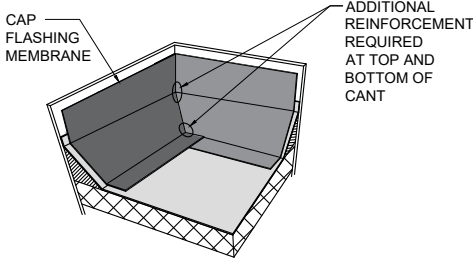

STEP 3

GENERAL NOTATIONS:

- For heat fused membrane applications, set metal flashing onto heated softened membrane.
- Extension of field base/plies 1" min above top of cant, required(not shown for clarity).
- Membrane end laps to be a minimum 6" and fully adhered at all membrane to membrane seams.
- Membrane laps at flanged metal to be 3" minimum and fully bonded to primed metal surface.

Roofing Details

Velociflex Mechanically Attached Base Ply Fastening Pattern 6" – PG-BASE-003

ZONE 1

- ONE (1) ROW WITHIN THE CENTER OF THE SIDE LAPS SPACED AT 6" O.C.

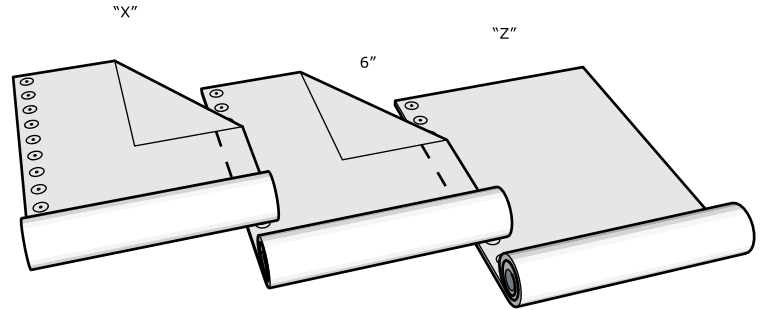

ZONE 2

- NOMINAL 60% OF FIELD ROW SPACING
- ONE (1) ROW WITHIN THE CENTER OF THE SIDE LAPS SPACED AT 6" O.C.
- ONE (1) INTERMEDIATE ROW, WITH FASTENERS SPACED 6" O.C. AND STAGGERED

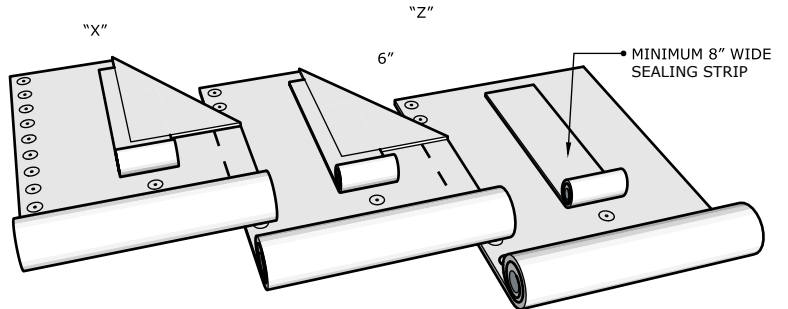

ZONE 3

- NOMINAL 40% OF FIELD ROW SPACING
- ONE (1) ROW WITHIN THE CENTER OF THE SIDE LAPS SPACED AT 6" O.C.
- TWO (2) INTERMEDIATE ROWS, WITH FASTENERS SPACED 6" O.C. AND STAGGERED

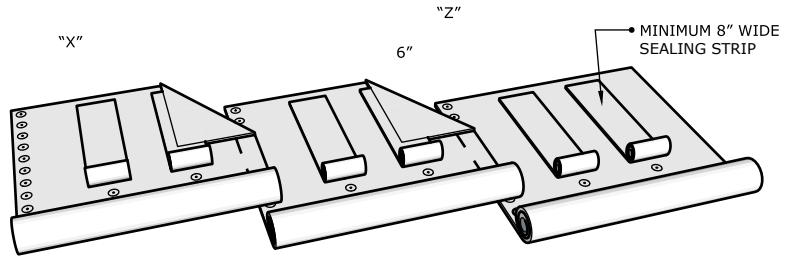

Roll Width (Y)	Lap Width (Z)	Zone	Pattern	Row Spacing (X)	Fasteners Per Square
39 in (1m)	4 in	1	6	35 in	69
		2	6, 6	17.5 in	138
		3	6, 6, 6	11.67 in	206
39 in (1m)	5 in	1	6	34 in	71
		2	6, 6	17 in	142
		3	6, 6, 6	11.33 in	212
39 in (1m)	6 in	1	6	33 in	73
		2	6, 6	16.5 in	146
		3	6, 6, 6	11 in	219

Velociflex Mechanically Attached Base Ply Fastening Pattern 12" – PG-BASE-003

ZONE 1

- ONE (1) ROW WITHIN THE CENTER OF THE SIDE LAPS SPACED AT 12" O.C.

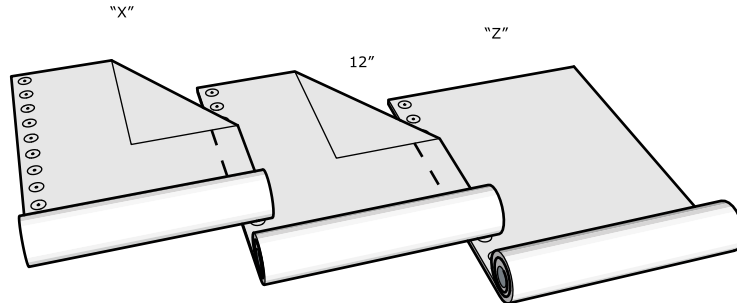

ZONE 2

- NOMINAL 60% OF FIELD ROW SPACING
- ONE (1) ROW WITHIN THE CENTER OF THE SIDE LAPS SPACED AT 12" O.C.
- ONE (1) INTERMEDIATE ROW, WITH FASTENERS SPACED 12" O.C. AND STAGGERED

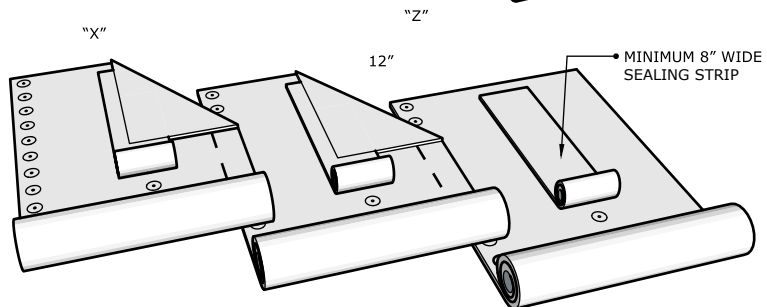

ZONE 3

- NOMINAL 40% OF FIELD ROW SPACING
- ONE (1) ROW WITHIN THE CENTER OF THE SIDE LAPS SPACED AT 12" O.C.
- TWO (2) INTERMEDIATE ROWS, WITH FASTENERS SPACED 12" O.C. AND STAGGERED

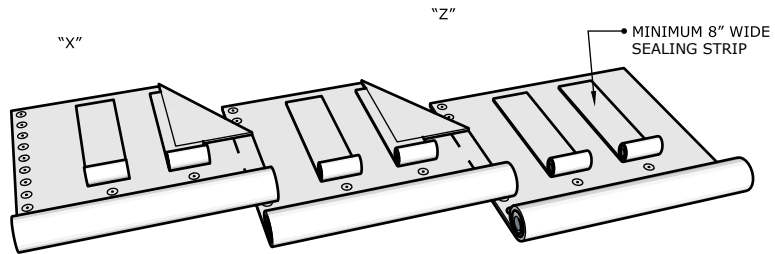

Roll Width (Y)	Lap Width (Z)	Zone	Pattern	Row Spacing (X)	Fasteners Per Square
39 in (1m)	4 in	1	12	35 in	35
		2	12, 12	17.5 in	69
		3	12, 12, 12	11.67 in	103
39 in (1m)	5 in	1	12	34 in	36
		2	12, 12	17 in	71
		3	12, 12, 12	11.33 in	106
39 in (1m)	6 in	1	12	33 in	37
		2	12, 12	16.5 in	73
		3	12, 12, 12	11 in	110

Roofing Details

Velociflex Mechanically Attached Base Ply Fastening Pattern 18" – PG-BASE-003

ZONE 1

- ONE (1) ROW WITHIN THE CENTER OF THE SIDE LAPS SPACED AT 18" O.C.

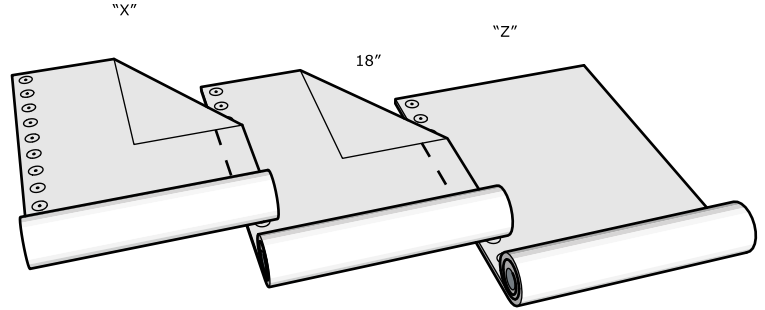

ZONE 2

- NOMINAL 60% OF FIELD ROW SPACING
- ONE (1) ROW WITHIN THE CENTER OF THE SIDE LAPS SPACED AT 18" O.C.
- ONE (1) INTERMEDIATE ROW, WITH FASTENERS SPACED 18" O.C. AND STAGGERED

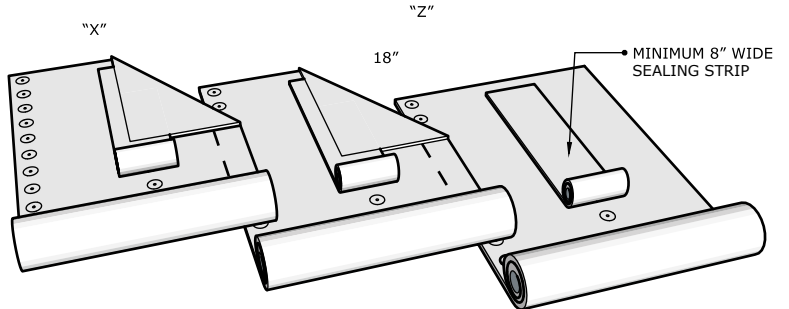

ZONE 3

- NOMINAL 40% OF FIELD ROW SPACING
- ONE (1) ROW WITHIN THE CENTER OF THE SIDE LAPS SPACED AT 18" O.C.
- TWO (2) INTERMEDIATE ROWS, WITH FASTENERS SPACED 18" O.C. AND STAGGERED

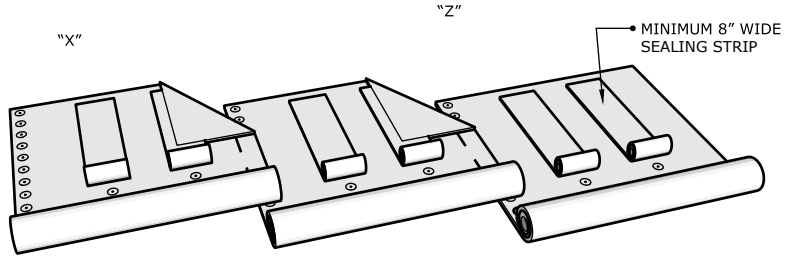

Roll Width (Y)	Lap Width (Z)	Zone	Pattern	Row Spacing (X)	Fasteners Per Square
39 in (1m)	4 in	1	18	35 in	23
		2	18, 18	17.5 in	46
		3	18, 18, 18	11.67 in	69
39 in (1m)	5 in	1	18	34 in	24
		2	18, 18	17 in	48
		3	18, 18, 18	11.33 in	71
39 in (1m)	6 in	1	18	33 in	25
		2	18, 18	16.5 in	49
		3	18, 18, 18	11 in	73

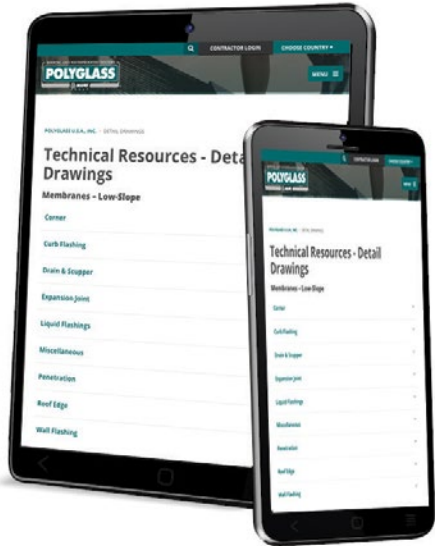

Scan to view Detail Drawings online

STEEP-SLOPE



Product Range

Polystick® Underlayments with ADESO® Technology

Polystick roof underlayments feature our revolutionary ADESO Technology, a patented method of manufacturing dual-compound self-adhesive membranes featuring enhanced lap sealing, designed to provide unmatched waterproofing across a wide range of roofing applications. This unique formulation includes an aggressive self-adhering bottom layer coupled with one of several types of top surfaces, depending on the application and waterproofing needs. No other underlayment on the market is made with this unique formulation, and none can surpass its level of protection.

Product	Mat	ASTM	Basic Use	Top Surface	Bottom Surface	Application
Polystick® XFR	Fiberglass	D1970	Underlayment	Film	Release Film	Self-Adhered
Polystick® MTS PLUS	Fiberglass	D1970	Underlayment	Film	Release Film	Self-Adhered
Polystick® TU MAX	N/A	D1970	Underlayment	Polyester Fabric	Release Film	Self-Adhered
Polystick® TU PLUS	Fiberglass	D1970	Underlayment	Polyester Fabric	Release Film	Self-Adhered
Polystick® TU P	Polyester	D1970	Underlayment	Mineral	Release Film	Self-Adhered
Polystick® P	N/A	D1970	Underlayment	Film	Release Paper	Self-Adhered
Polystick® IR-Xe	Fiberglass	D1970	Underlayment	Mineral/Sand	Release Film	Self-Adhered

Non-Modified Base, Felt and Anchor Sheets

Product	Mat	ASTM	Basic Use	Top Surface	Bottom Surface
PolyAnchor®	N/A	D226, Type I	Anchor Sheet	Film	Film
Polyglass® G2 Base	Fiberglass	D4601	Base/Interply	Sand	Sand
Polyglass® Ply IV	Fiberglass	D2178	Interply	Sand	Sand
Polyglass® Ply VI	Fiberglass	D2178	Interply	Sand	Sand

Product Range



Net Coverage (Approx)	Gross Coverage (Actual)	Weight	Nominal Thickness	Length	Width	Rolls/Pallet	UL
150 ft ² (13.9 m ²)	160 ft ² (15 m ²)	75 lbs (34 kg)	80 mils (2.0 mm)	49'3" (15 m)	39 3/8" (1 m)	20	✓
200 ft ² (18.5 m ²)	215 ft ² (20 m ²)	74 lbs (33.5 kg)	60 mils (1.5 mm)	65'8" (20 m)	39 3/8" (1 m)	30	✓
200 ft ² (18.5 m ²)	215 ft ² (20 m ²)	70 lbs (32 kg)	60 mils (1.5 mm)	65'8" (20 m)	39 3/8" (1 m)	25	
200 ft ² (18.5 m ²)	215 ft ² (20 m ²)	79 lbs (36 kg)	80 mils (2.0 mm)	65'8" (20 m)	39 3/8" (1 m)	25	✓
100 ft ² (9.3 m ²)	108 ft ² (10 m ²)	86 lbs (39 kg)	130 mils (3.3 mm)	32'10" (10 m)	39 3/8" (1 m)	20	
180 ft ² (16.7 m ²)	200 ft ² (18.5 m ²)	56 lbs (25 kg)	42 mils (1.07 mm)	65'11" (20.1 m)	36 1/4" (0.92 m)	20	
180 ft ² (16.7 m ²)	195 ft ² (18.2 m ²)	56 lbs (25 kg) mineral 61 lbs (28 kg) sand	60 mils (1.5 mm)	65'4" (19.9 m)	36" (0.914 m)	30	✓



Application	Gross Coverage (Actual)	Weight	Length	Width	Rolls/Pallet	UL
Mechanically Attached	1,000 ft ² (93 m ²)	34 lbs (15.4 kg)	250' (76.2 m)	48" (1.2 m)	20	✓
Hot Mop/Mechanically Attached	325 ft ² (30 m ²)	78 lbs (35.4 kg)	108' (33 m)	36" (0.914 m)	20	✓
Hot Mop/Mechanically Attached	540 ft ² (50.2 m ²)	40 lbs (18.1 kg)	180' (55 m)	36" (0.914 m)	20	✓
Hot Mop/Mechanically Attached	540 ft ² (50.2 m ²)	45 lbs (20.4 kg)	180' (55 m)	36" (0.914 m)	20	✓

General Requirements and Design Criteria

Part 1: Low Slope General Requirements	63
1.0 General	63
1.1 Quality Assurance	63
1.2 Material Handling and Storage	63
1.3 Limitations	63
Part 2: Steep-Slope Roofing Materials	63
2.0 Anchor Sheet	63
2.1 Polyglass Polystick Self-Adhered Roof Underlayments	63
2.2 Finishing Roof Cover (by Others)	63
2.3 Asphalt Primers	64
2.4 Modified Asphalt Adhesives	64
Part 3: Steep-Slope Membrane Installation	64
3.0 Surface Preparation	64
3.1 Re-Roofing Applications	64
3.2 Application of Mechanically Attached Sheet (Non-Direct to Deck)	64
3.3 Application of Polystick Underlayment	64

General Requirements and Design Criteria

Part 1: Steep-Slope

General Requirements

1.0 General

Provide all labor, materials, equipment, supervision, and incidentals as needed to install a complete Polyglass® reinforced modified bituminous underlayment over a new or accepted prepared existing roof substrate. All details of installation shall conform to Polyglass Specifications, Details and General Recommendations.

1.1 QUALITY ASSURANCE

- A. Products used in the work of this Section shall be manufactured by Polyglass or accepted for use in conjunction with the products manufactured by Polyglass.
- B. The Roofing Contractor shall be currently accepted by Polyglass as qualified to install the materials of this section to receive a Polyglass warranty.
- C. Do not apply roofing during inclement weather. Do not apply roofing membrane to damp, frozen, dirty or dusty surfaces.
- D. Installation of any Polyglass Polystick® Self-Adhered Underlayment system shall be at the lowest point of the roof (or roof area), working up the slope toward the highest point. Lap sheets in shingle fashion to constantly shed water. For further information contact Polyglass Technical Services. Follow the recommendations for the specific type of material and layer as outlined below, or as specified. NOTE: Some applications may require the acceptable application method of strapping the roof as constructed.

1.2 Material Handling and Storage

- A. All materials, except those that are shop fabricated shall be delivered to the job site with their original labels intact. Bulk materials shall be identified by the manufacturer as to specification issued.
- B. All materials shall be stored in accordance with the instructions of the manufacturer prior to their application or installation. No wet or damaged materials will be used in the application. Materials stored on the job site shall be a minimum 4" (10 cm) off the ground of the roof.
- C. Polyglass Polystick self-adhered underlayments are to be stored at room temperature whenever possible and in an upright position on a flat surface. Avoid storing out of packaging for prolonged periods, especially above 88°F (31°C), in direct sunlight. Do not take the Polystick underlayment roll out of the packaging until it is ready for application. Refer to technical bulletins found at www.polyglass.us for more instruction on storage and handling.
- D. Application of all roofing shall be accomplished in such a way that each area will be complete at the end of each day's work. All roof edges and incomplete flashing shall be protected against water entry, particularly between work periods.
- E. When ambient temperature is below 40°F (5°C), care must be exercised in handling and storing

Polyglass products. Only products for immediate application shall be exposed to the elements.

- F. All masonry, concrete and sheet metal surfaces incorporated into the roof system shall be primed with Polyglass PG-100 asphalt primer meeting ASTM D-41 specification and allowed to dry prior to installing bituminous roofing materials.
- G. Wood curbs or nailers, where required, shall be pressure treated with accepted pressure treatment meeting AWWAP Standard P-5.

1.3 Limitations

IMPORTANT NOTE: Use extreme care when using open flame torches or similar devices when used in areas of combustible materials.

Part 2: Steep-Slope Roofing Materials

2.0 Anchor Sheet

Any mechanically attached base sheet or anchor sheet, as approved or deemed applicable per project requirements.

2.1 Polyglass Polystick Self-Adhered Roof Underlayments

Polyglass Polystick Self-Adhered roof underlayments are homogeneous rubberized asphalt membranes (fiberglass or polyester reinforced, or non-reinforced) designed for specific applications as a waterproofing underlayment. The bottom surface of the sheet has an adhesive compound with split release film for ease of application. Typically, Polystick underlayments are 200 ft² (18.5 m²) net coverage (approximate) or 215 ft² (20 m²) gross coverage (actual) per roll and weigh approximately 75 lbs (34 kg).

2.2 Finishing Roof Cover (by Others)

Roofing Tiles (6 Max. Per Stack)
Tejas para techo (máximo de 6 tejas apiladas)

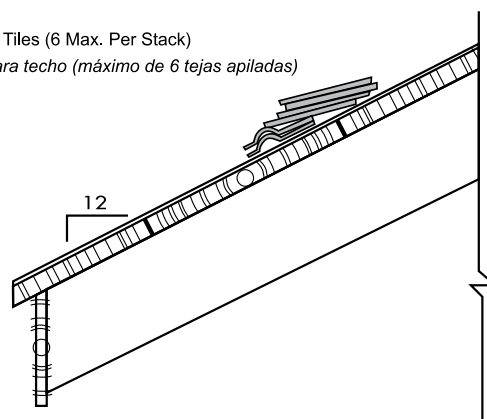

- A. Clay, ceramic, concrete, or other roofing tiles, manufactured by others, maybe set in foam adhesives, mortar, or mechanically attached. Battens are approved for use for Tile applications as well as Tile stacking/loading. NOTE: Polyglass does provide detailed instructions for Tile stacking. Tile stacking instruction can be found on packaging, within certain building code documentations (as applicable) and online at www.polyglass.us.
- B. Mechanically attached metal roofing systems, shingles, shakes and other approved/accepted finished roofing products.

General Requirements and Design Criteria

2.3 Asphalt Primers

Polyglass PG 100 Fast Drying Asphalt Primer or any other ASTM D-41 asphaltic primer, PolyBrite® 745 Water-Based Primer/Adhesive or WB 3000 Water Based Primer; applied in strict conformance to manufacturers recommendations.

2.4 Modified Asphalt Adhesives

Polyglass PolyPlus® 50 Premium Modified Wet/Dry Cement or PG 500 Modified Cement; applied in strict conformance to Polyglass installation instructions. Use is required for certain Polyglass Warranty programs.

Part 3: Steep-Slope Membrane Installation

3.0 Surface Preparation

The roof surface, which is to receive the Polystick underlayment, shall be smooth, clean, free from loose gravel, dirt, and debris, dry and structurally sound.

Application of Polyglass Polystick Self-Adhered Underlayment – Direct to Deck

NOTE: Where required, prime in accordance with requirements and recommendations of the primer and priming materials manufacturer (if applicable). Typically, recover boards must be field primed.

3.1 Re-Roofing Applications

- A. Remove existing metal edging down to the surface of the roof. Remove existing flashings at roof details and roof penetrations. Remove all wet or deteriorated roofing substrate materials or insulation and fill in any low spots that may occur as a result of any removal work, to create a smooth even surface for application of underlayments.
- B. Existing roof surfaces shall be primed as necessary with Polyglass PG 100 Fast Drying Asphalt Primer or any other ASTM D-41 asphaltic primer, PolyBrite 745 Water-Based Primer/ Adhesive or WB 3000 Water Based Primer and allowed to dry prior to installing the Polystick membrane underlayment, applied in strict conformance to manufacturers recommendations.

3.2 Application of Mechanically Attached Sheet (Non-Direct to Deck)

- A. Directly over the acceptable substrate/insulation install one ply of approved, nailable base sheet with minimum 3" (7.5 cm) side laps and minimum 6" (15 cm) end laps. Seams and all laps shall be without wrinkles or fishmouths.
- B. The base sheet shall be mechanically fastened with approved fastening systems, appropriate for the specific deck type and thickness. Length to be as determined as per required penetration of deck.
- C. Where a vapor retarder, slip or base sheet is required by the specifier, follow the instructions regarding the particular materials specified and install in accordance with the recommendations of the manufacturer and the requirements of the architect.

3.3 Application of Polystick Underlayment

Directly over the acceptable substrate/insulation/anchor sheet, install one ply of Polystick underlayment. Polystick underlayments shall be installed without wrinkles or fishmouths. Unless the substrate surface is flat, voids may occur which will be hard to seal and may not render a permanent, waterproof roof. It is the installer's responsibility to ensure that substrate conditions permit a wrinkle and void-free installation. Any voids occurring may have to be sealed with a heat gun or an application of Polyglass PolyPlus® 50 Premium Modified Wet/Dry Cement or PG 500 Modified Cement. Starting from the lowest point of the roof, cut and unroll the membrane to a suitable desired length (depending on conditions).

- A. Position the material in the desired location on the substrate, align the membrane at the lowest edge of the roof.
- B. Fold the material back onto itself (width wise) and remove the split back release paper from the exposed side, gradually push/roll the material into place (do not lift and drop the material into place, air pockets may occur that will be difficult to remove).
- C. Apply even pressure along the entire length of the membrane, from center to outer edges, to avoid air inclusions or wrinkles. Repeat for other side.
- D. Polystick underlayments require specific back nailing attachments. These attachments are dictated by the slope of the roof. Please follow the Polyglass published back nailing guides, as published in this manual or online at www.polyglass.us.
- E. Position successive rolls providing a minimum 6" (15 cm) end lap and 3" (7.5 cm) side lap. Position the next sheet by overlapping seams to lineup the overlap of the top sheet edge with the inside of the bottom sheet's factory selvage edge. Repeat the above procedure for all subsequent sheets. At side overlaps, remove the protective seam tape (if applicable) and apply even pressure to seam area. Exception: Polystick® TU PLUS must line up with the guideline at the bottom of the nail area. Reference product specific applications listed on Product Data Sheets.
- F. After adhering the Polystick underlayment, uniform pressure must be applied to the entire surface. Roll area with a 35 lbs (16 kg) or 75 lbs (34 kg) weighted roller, or water-filled lawn roller. Brooming the surface of the Polystick membrane is also acceptable on steep pitched roof applications where safety is a concern. NOTE: Polyglass advises that proper safety precautions are taken during rolling on all sloped roofs.
- G. Polystick membranes shall be installed perpendicular to the slope of the roof, starting at the lowest point of application, wherever possible. Laps of sheets should be installed to shed water with the slope of the roof wherever practical. NOTE: Strapping of the Polystick underlayment is acceptable in certain applications.
- H. Additional applications of certain Polystick underlayments are applicable when applied directly to an installed layer of either Polystick® MTS Plus or Polystick® XFR.

General Requirements and Design Criteria

- I. At any intersection between different roof slopes, narrow valleys or gutters (less than 3' (0.9 m) wide) or similar details, require an initial ply of Polystick MTS Plus, Polystick XFR or Elastoflex SA V under the applicable Polystick underlayments, extending minimum 6" (15 cm) onto each surface. Polyglass recommends that all metal flashing components be contained and sealed between pieces of Polystick underlayment.
- J. When installing and applying finishing roof covering (metal, shingle, tile, etc.) by Others, review the Manufacturers Specifications and/or Local Building Codes.

Guide Specifications

1-Ply Systems

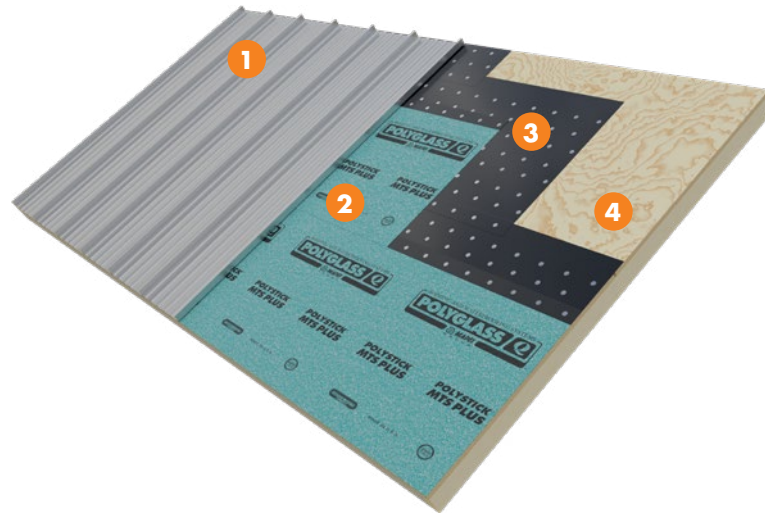

1-Ply Polystick MTS PLUS

1. **Roof Covering:** Metal Roofing (by others)
2. **Base Ply Underlayment:** Polystick MTS PLUS
3. **Base Layer:** 30 lb. Sheet (per code)
4. **Roof Deck:** Approved/Accepted Substrate (prime when necessary)

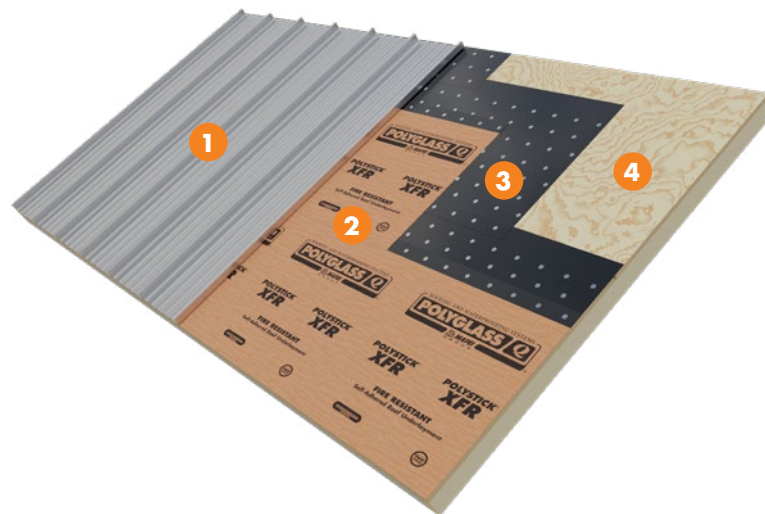

1-Ply Polystick XFR

1. **Roof Covering:** Metal Roofing (by others)
2. **Base Ply Underlayment:** Polystick XFR
3. **Base Layer:** 30 lb. Sheet (per code)
4. **Roof Deck:** Approved/Accepted Substrate (prime when necessary)

Guide Specifications

1-Ply Systems



1-Ply Polystick P

1. **Roof Covering:** Metal Roofing (by others)
2. **Base Ply Underlayment:** Polystick P
3. **Base Layer:** 30 lb. Sheet (per code)
4. **Roof Deck:** Approved/Accepted Substrate (prime when necessary)

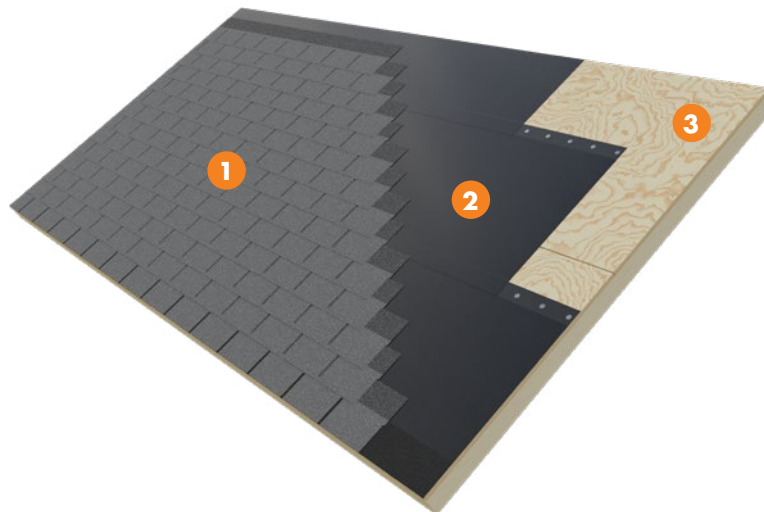

1-Ply Polystick IR-Xe

1. **Roof Covering:** Asphalt Shingles (by others)
2. **Base Ply Underlayment:** Polystick IR-Xe (sand or mineral)
3. **Roof Deck:** Approved/Accepted Substrate (prime when necessary)

Guide Specifications

1-Ply Systems

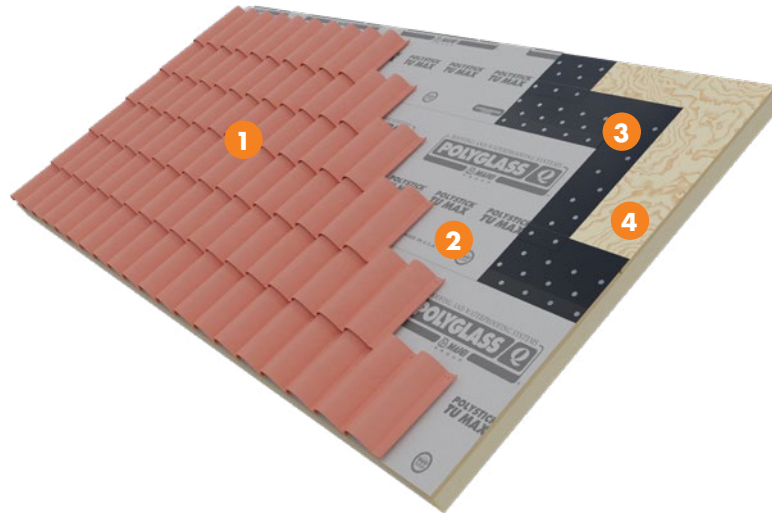

1-Ply Polystick TU MAX

1. **Roof Covering:** Roofing Tiles (by others)
2. **Base Ply Underlayment:** Polystick TU MAX
3. **Base Layer:** 30 lb. Base (per code)
4. **Roof Deck:** Approved/Accepted Substrate (prime when necessary)

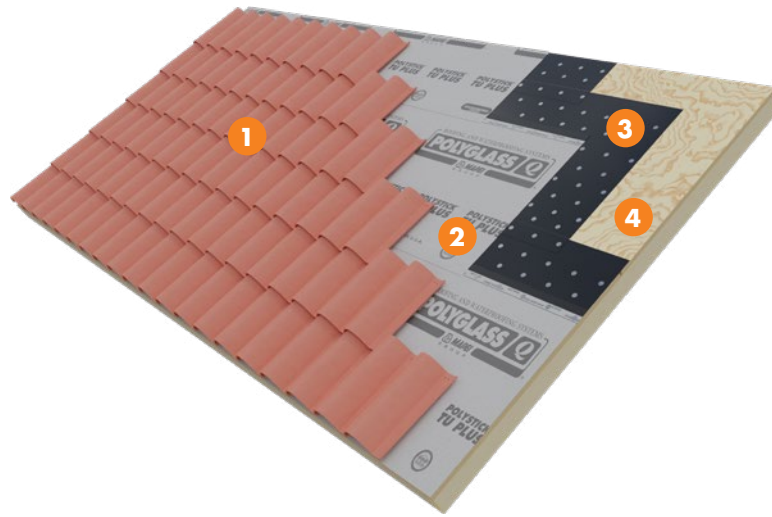

1-Ply Polystick TU PLUS

1. **Roof Covering:** Roofing Tiles (by others)
2. **Base Ply Underlayment:** Polystick TU PLUS
3. **Base Layer:** 30 lb. Base (per code)
4. **Roof Deck:** Approved/Accepted Substrate (prime when necessary)

Guide Specifications

2-Ply Systems

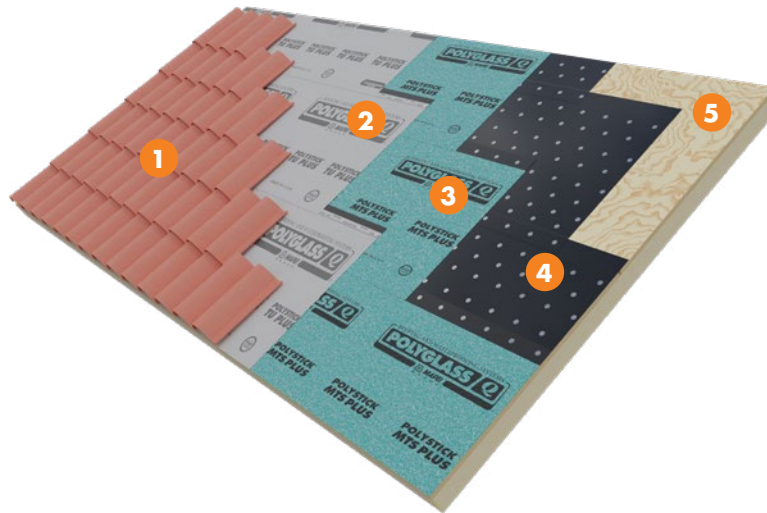

2-Ply Polystick TU PLUS/Polystick MTS PLUS

1. **Roof Covering:** Roofing Tiles (by others)
2. **Top Ply Underlayment:** Polystick TU PLUS or Polystick TU MAX
3. **Base Ply Underlayment:** Polystick MTS PLUS
4. **Base Layer:** 30 lb. Base (per code)
5. **Roof Deck:** Approved/Accepted Substrate (prime when necessary)

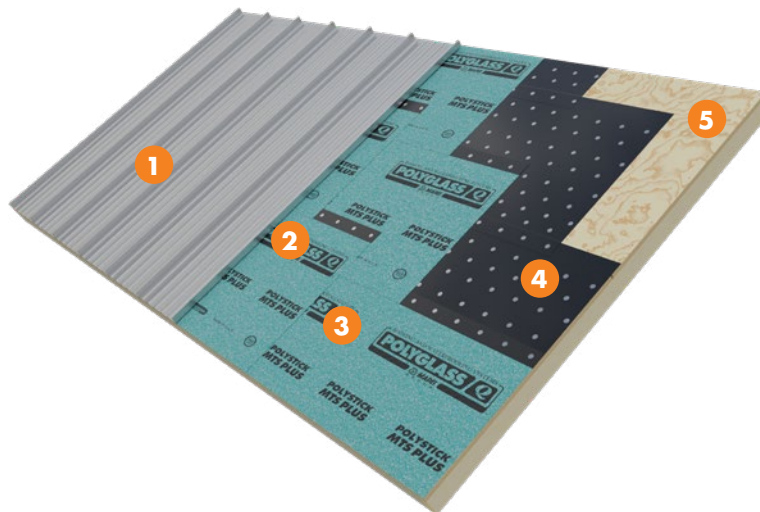

2-Ply Polystick MTS PLUS/Polystick MTS PLUS

1. **Roof Covering:** Metal Roofing (by others)
2. **Top Ply Underlayment:** Polystick MTS PLUS
3. **Base Ply Underlayment:** Polystick MTS PLUS
4. **Base Layer:** 30 lb. Base (per code)
5. **Roof Deck:** Approved/Accepted Substrate (prime when necessary)

Guide Specifications

2-Ply Systems

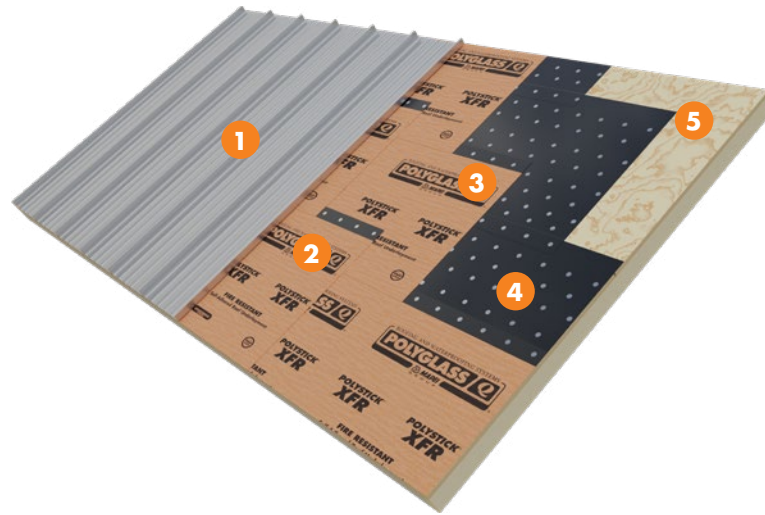

2-Ply Polystick XFR/Polystick XFR

1. **Roof Covering:** Metal Roofing (by others)
2. **Top Ply Underlayment:** Polystick XFR
3. **Base Ply Underlayment:** Polystick XFR
4. **Base Layer:** 30 lb. Base (per code)
5. **Roof Deck:** Approved/Accepted Substrate (prime when necessary)



Scan to view
Specifications online

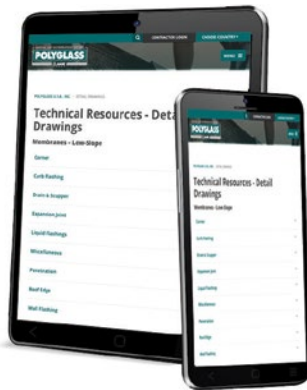

Scan to view
Detail Drawings online

VALLEY FLASHING DETAIL (Typical) – PG-SS-VLY-01

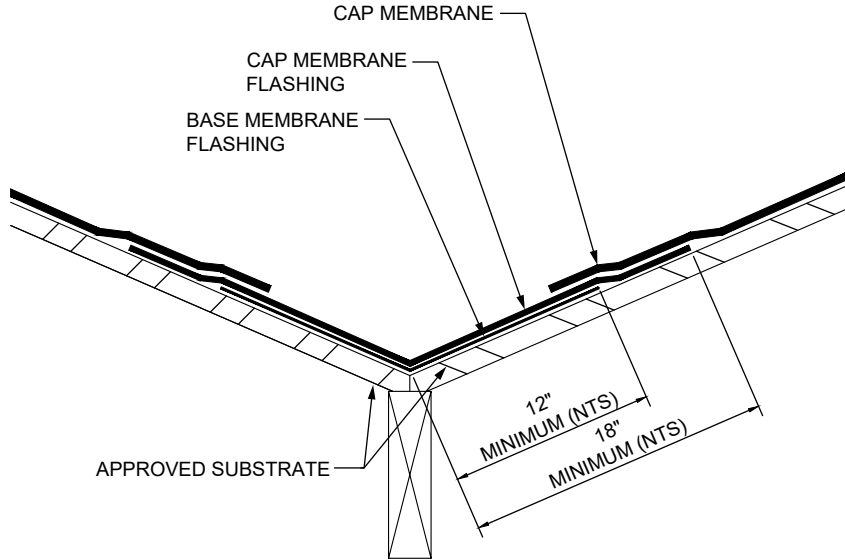

GENERAL NOTATIONS:

- Metal Edge Flashing, Wood Blockings and Attachments shall comply with ANSI/SPRI ES-1.
- Refer to SMACNA recommendations and details regarding metal thickness and cleat requirements. Continuous cleats are recommended at all edges and coping flashings, cleats to be at least one gauge heavier than the edge/coping metal.
- Wood blocking may be slotted for venting of wet-fill decks or other applicable constructions.
- For heat fused membrane applications, set metal flashing onto heated softened membrane.
- Extension of field base/plies 1" min above top of cant, required (not shown for clarity).
- Membrane end laps to be a minimum 6" and fully adhered at all membrane to membrane seams.
- Membrane laps at flanged metal to be 3" minimum and fully bonded to primed metal surface.
- Use only when roof deck is support by the wall.

STEEP-SLOPE TO LOW-SLOPE TRANSITION DETAIL (Typical) – PG-SS-VLY-02

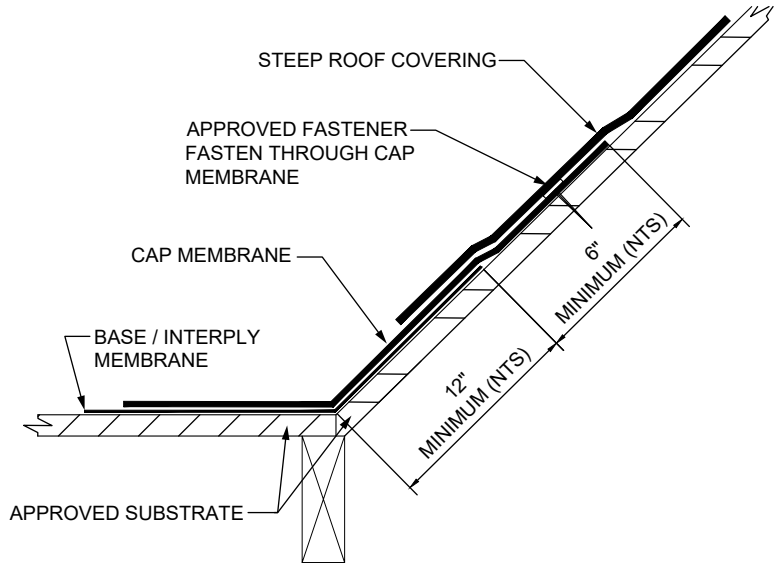

GENERAL NOTATIONS:

- Metal Edge Flashing, Wood Blockings and Attachments shall comply with ANSI/SPRI ES-1.
- Refer to SMACNA recommendations and details regarding metal thickness and cleat requirements. Continuous cleats are recommended at all edges and coping flashings, cleats to be at least one gauge heavier than the edge/coping metal.
- Wood blocking may be slotted for venting of wet-fill decks or other applicable constructions.
- For heat fused membrane applications, set metal flashing onto heated softened membrane.
- Extension of field base/plies 1" min above top of cant, required (not shown for clarity).
- Membrane end laps to be a minimum 6" and fully adhered at all membrane to membrane seams.
- Membrane laps at flanged metal to be 3" minimum and fully bonded to primed metal surface.
- Use only when roof deck is support by the wall.

POLYGLASS®



POLYGLASS U.S.A., Inc.

1111 West Newport Center Drive
Deerfield Beach, FL 33442

pgmarketing@polyglass.com

Customer Service: (800) 222-9782

Customer Success: (888) 975-1286

polyglass.us