



POLYFORZA COPING

EXISTING SLOPE VERSION - 2'-0" O.C.

INSTALLATION INSTRUCTIONS

IMPORTANT: PRIOR TO INSTALLATION, READ INSTRUCTIONS CAREFULLY.

NOTE: POSITION ROOF MEMBRANE ON TOP OF THE WALL COVERING THE TREATED WOOD NAILER(S) OR SUBSTRATE COMPLETELY. ALLOW 1/2" MINIMUM EXCESS MEMBRANE BEYOND NAILER WHERE APPLICABLE. NRCA REQUIREMENT.

CAUTION: INSTALL MITERS FIRST!

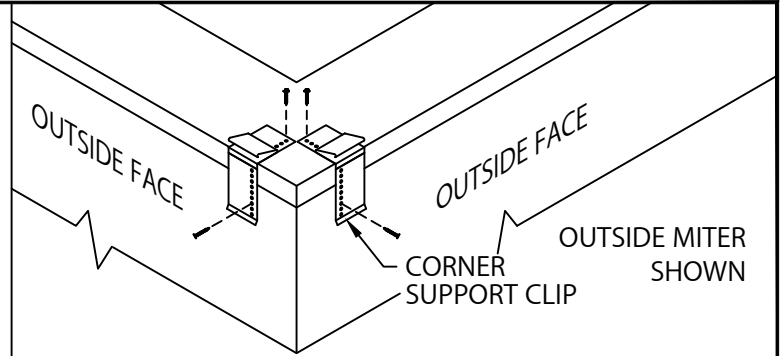

STEP 1 - CORNER SUPPORT CLIPS

LOCATE AND FASTEN GALVANIZED CORNER SUPPORT CLIPS TO THE WALL.

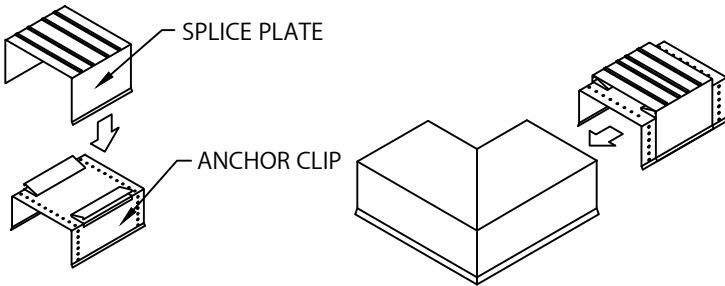

STEP 2 - MITER SPLICE PLATES & ANCHOR CLIPS

REMOVE RELEASE PAPER FROM SPLICE PLATE SEALANT STRIPS. POSITION THE SPLICE PLATE IN THE CENTER OF THE ANCHOR CLIP. INSTALL THE SPLICE PLATE AND ANCHOR CLIP ASSEMBLY INTO EACH END OF THE CORNER AS SHOWN.

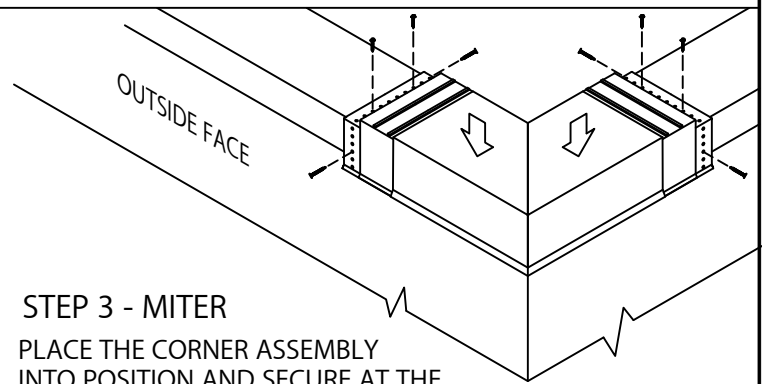

STEP 3 - MITER

PLACE THE CORNER ASSEMBLY INTO POSITION AND SECURE AT THE EXPOSED EDGE OF THE ANCHOR CLIPS AS PER DETAIL A.

LEFT ENDCAP SHOWN

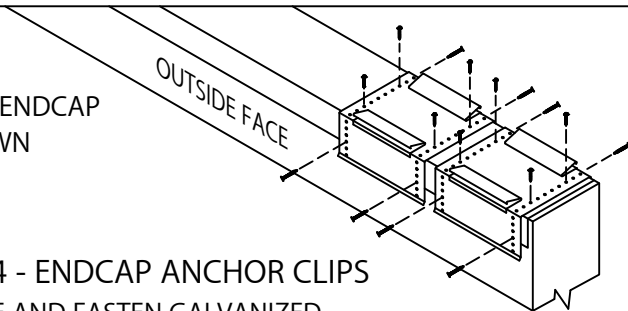

STEP 4 - ENDCAP ANCHOR CLIPS

LOCATE AND FASTEN GALVANIZED ANCHOR CLIPS TO WALL WITH PROVIDED FASTENERS FOR SUBSTRATE (SEE DETAIL A).

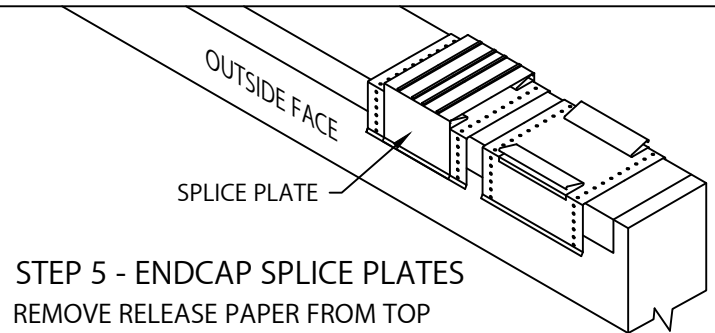

STEP 5 - ENDCAP SPLICE PLATES

REMOVE RELEASE PAPER FROM TOP OF FACTORY APPLIED SEALANT STRIPS. PLACE SPLICE PLATE ONTO SECOND ANCHOR CLIP AS SHOWN.

STEP 6 - ENDCAP

HOOK OUTSIDE FACE OF ENDCAP OVER THE ANCHOR CLIPS AND ROTATE INTO PLACE. ENGAGE REAR LEG ONTO ANCHOR CLIPS BY PRESSING DOWNWARD UNTIL SNAP LOCK OCCURS.

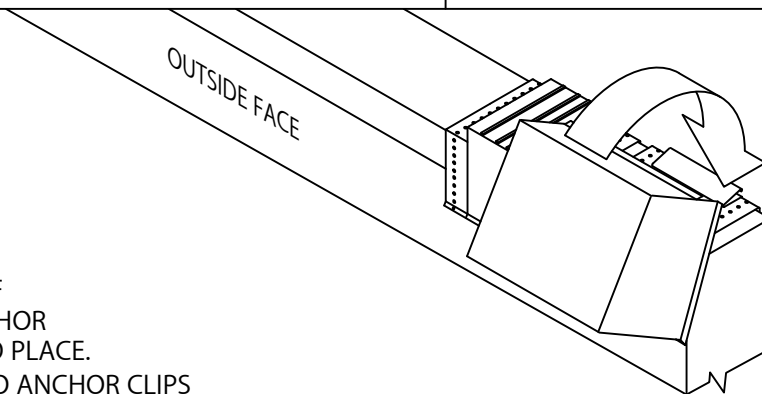

polyglass.us
1111 West Newport Center Drive
Deerfield Beach, FL 33442
Technical Service: (866) 794-9659
technical@polyglass.com

DATE: 08/01/22

DRN BY: MLM

CKD BY: MM

SHT.# 1 OF 3

DWG# 45111-39200

A



POLYFORZA COPING

EXISTING SLOPE VERSION - 2'-0" O.C.

INSTALLATION INSTRUCTIONS

INSTALLATION NOTES:

1) Installing contractor shall check as-built conditions, including nailer attachment, and verify the manufacturer's coping details for accuracy to fit the wall assembly prior to fabrication.

2) Fasteners must be corrosion resistant and rated for a minimum 250# pullout force for the substrate that is being used.

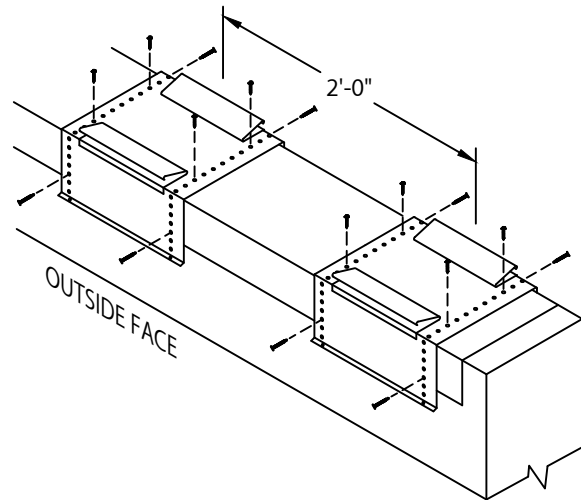

STEP 7 - ANCHOR CLIPS

LOCATE AND FASTEN GALVANIZED ANCHOR CLIPS TO WALL AT 2'-0" CENTERS WITH PROVIDED FASTENERS FOR SUBSTRATE (SEE DETAIL A).

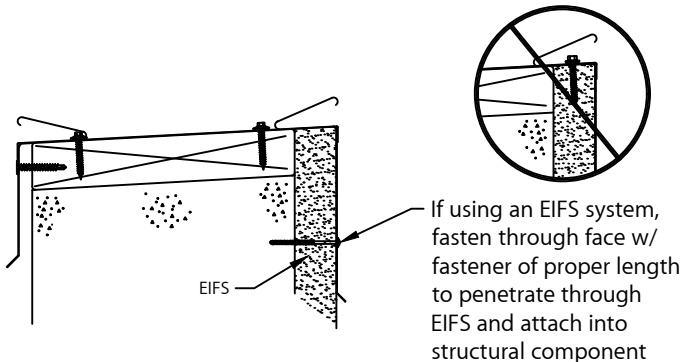

If using an EIFS system, fasten through face w/ fastener of proper length to penetrate through EIFS and attach into structural component

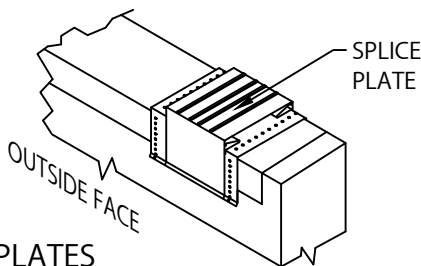

STEP 8 - SPLICE PLATES

PLACE SPLICE PLATE ONTO ANCHOR CLIPS AT SPLICE JOINTS, 12'-0" O.C.

NOTE: REMOVE RELEASE PAPER FROM SEALANT STRIPS.

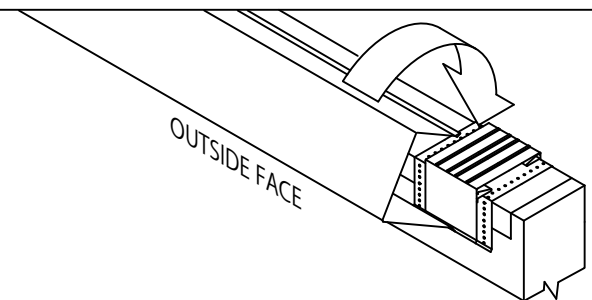

STEP 9 - COPING

HOOK OUTSIDE FACE OF COPING OVER THE ANCHOR CLIPS AND ROTATE INTO PLACE. ENGAGE REAR LEG ONTO ANCHOR CLIPS BY PRESSING DOWNWARD UNTIL SNAP LOCK OCCURS.

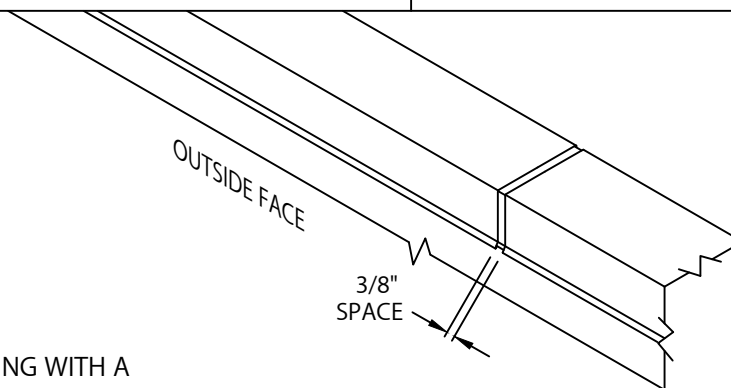

STEP 10 - COMPLETION

CONTINUE INSTALLING COPING WITH A 3/8" SPACE AT SPLICE JOINTS TO ALLOW FOR THERMAL EXPANSION. FIELD CUT WHERE NECESSARY USING FINE TOOTH HACKSAW OR SNIPS.

NOTE: REMOVE PROTECTIVE FILM IMMEDIATELY.



polyglass.us
1111 West Newport Center Drive
Deerfield Beach, FL 33442
Technical Service: (866) 794-9659
technical@polyglass.com

DATE: 08/01/22

DRN BY: MLM

CKD BY: MM

SHT.# 2 OF 3

DWG# 45111-39200

A



POLYFORZA COPING

EXISTING SLOPE VERSION - 2'-0" O.C.

INSTALLATION INSTRUCTIONS

TYPICAL COPING INSTALLATION DETAIL A

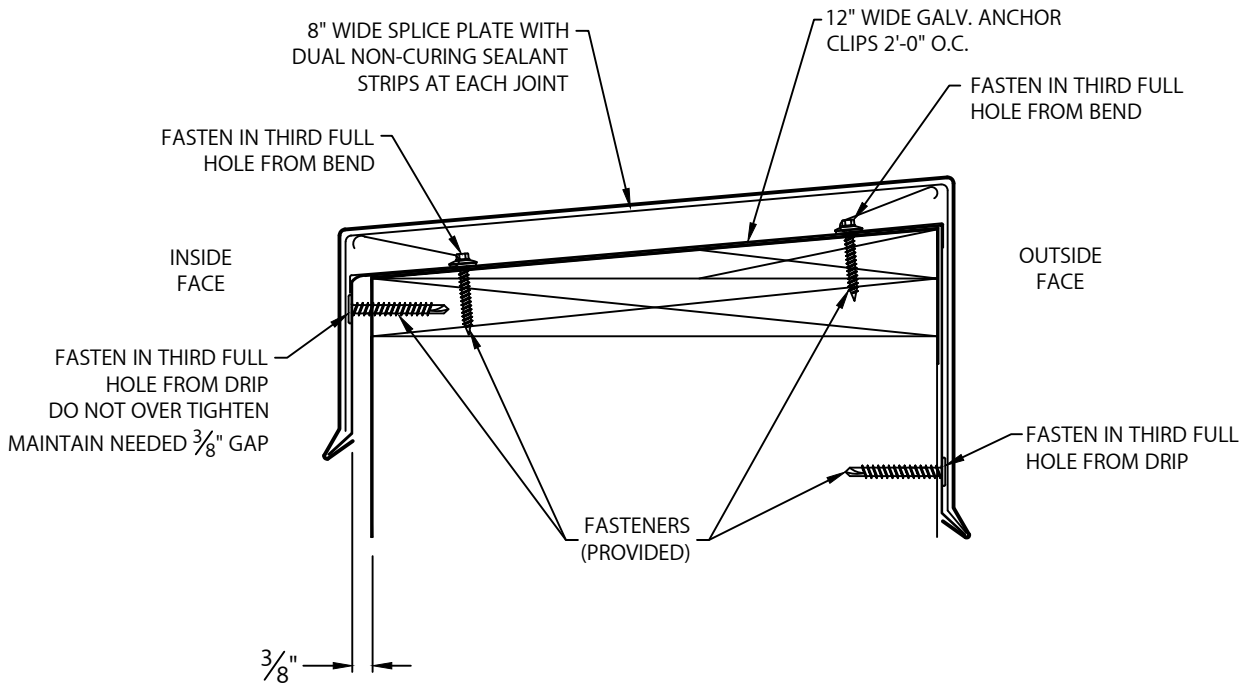

polyglass.us
 1111 West Newport Center Drive
 Deerfield Beach, FL 33442
 Technical Service: (866) 794-9659
 technical@polyglass.com

DATE: 08/01/22
 DRN BY: MLM
 CKD BY: MM

SHT.# 3 OF 3
 DWG# 45111-39200 **A**